

— • ≡ S S ≡ N Z I A L E ≡

L E S S .
is more

Il principio delle forme, del design, dei materiali e della luce. *'Less is more'* è una filosofia che viene applicata alla vita ma anche alle forme architettoniche, con la finalità di raggiungere la massima funzionalità e semplicità delle linee, senza aggiungere nulla di più. *'Less is more'* è anche uno stile deciso, dato dall'animo contrastato della porta in vetro: unisce l'ambiente e allo stesso tempo separa gli spazi, resiste al dinamismo

The concept of shapes, design, materials and light.
'Less is more' is a philosophy applied to life but also to the architectural shapes, aimed to achieve the maximum functionality and simplicity of lines, without adding anything else.
'Less is more' is also a resolute style, given by the contrasting glass door core: it joins the room while separating space, resisting daily dynamics while remaining lightweight, its matter does not hinder but illuminates

quotidiano restando leggera, la sua materialità non ostacola ma illumina e le sue linee minimal arricchiscono senza togliere nulla all'ambiente. Ad ogni ora la casa si arricchisce di una luce nuova svelando la bellezza degli spazi. Il passaggio dalla luce calda del mattino, fino alla luce fioca della sera, viene visto attraverso il vetro, a volte trasparente, altre satinato, ma sempre essenziale. Il mutare della luce l'abbiamo riprodotto nel catalogo per raccontare la storia della casa.

and its minimal lines enrich without taking away from the room. The home is embellished by a new light revealing the beauty of its space any time of day. The shift from the warm morning light to the dim evening light is seen through the glass, at times transparent, others frosted, but always essential. We reproduced the changing light in the catalogue to tell the story of the home.

6

8

46

48

50

60

66

Descrizione linea
Line description

Mono
Mono

Dettagli tecnici
Technical details

Modelli
Models

Finiture
Finishes

Disegni tecnici
Technical draws

Maniglie
Handles

7

68

90

92

96

102

Descrizione linea
Line description

Duo
Duo

Dettagli tecnici
Technical details

Finiture
Finishes

Disegni tecnici
Technical draws

Maniglie
Handles



IMMAGINE ANAMORFICA

Appoggia il catalogo su una superficie e inquadra con la camera, del tuo smartphone o tablet, per vedere l'immagine in 3D

ANAMORPHIC IMAGE

Rest the catalogue on a flat surface and observe it through a camera lens, your smartphone or tablet to see the image in 3D

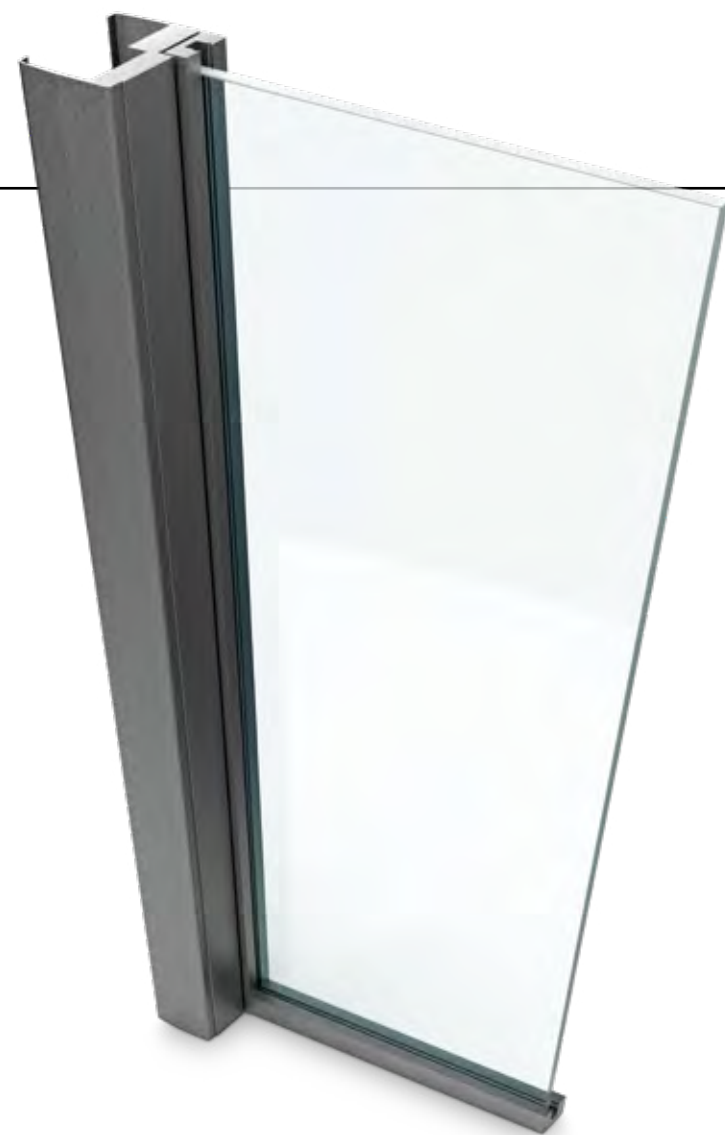

MONO

Collezione di porte a vetro singolo, ad una o più ante.
Il vetro temperato è disponibile con uno spessore da 8 mm o 4+4 mm, può essere personalizzato con varie soluzioni cromatiche e con lavorazioni di sabbiatura, incisione e stampa digitale.
Le versioni realizzabili sono: battente, battente minimale, scorrevole a scomparsa, scorrevole rasomuro, scorrevole esterno, scorrevole Zero, Pivot, pieghevole a 2, 3 o 4 ante.

Tutti i vetri sono certificati secondo le normative di sicurezza UNI 7697 e UNI EN 12600.

*Single glass door collection with one or more leaves.
The tempered glass is available with thickness from 8 mm or 4+4 mm, it can be customised with various colour solutions and sanded, engraved or digital print finish.
Available versions include: hinged, minimal hinged, pocket sliding, rasomuro sliding, external sliding
Zero sliding, Pivot, folding with 2, 3 or 4 leaves.*

All glass is certified according to UNI 7697 and UNI EN 12600 safety regulations.



DUO

Collezione di porte a vetro doppio, ad una o più ante.
Il vetro temperato è di spessore 5 mm, per le porte a battente si possono raggiungere i 240 cm di altezza, mentre per le scorrevoli si arriva fino a 270 cm. Oltre a porta a battente, scorrevole a scomparsa e varie tipologie di scorrevoli esterni è disponibile anche la versione pieghevole a 2 o 3 ante.

Tutti i vetri sono certificati secondo le normative di sicurezza UNI 7697 e UNI EN 12600.

*Double glass door collection with one or more leaves.
The tempered glass is available with 5 mm thickness, for hinged doors it can reach 240 cm in height, while for sliding doors it can reach up to 270 cm. In addition to hinged, pocket sliding and various types of external sliding the folding version with 2 or 3 leaves is also available.*

All glass is certified according to UNI 7697 and UNI EN 12600 safety regulations.

MONO

Uno, come il vetro singolo che riesce ad illuminare un ambiente intero. Quando la leggerezza diventa l'elemento fondamentale in un ambiente, si ha il raggiungimento del benessere e della stabilità. **S-nziale Mono** è lo stile che supera le forme e abbraccia la personalizzazione delle incisioni e dei decori, in un'unica superficie.

*One, like the single glass that can illuminate the entire room. Wellness and stability can be achieved when levity becomes a fundamental element in a room. **S-nziale Mono** is the style that exceeds shapes and embraces the customisation of the engravings and decorations in a single surface.*

S00

Battente TRATTO
Alluminio: argento
Vetro: laccato rosso

TRATTO hinged
Aluminium: silver
Glass: red lacquered



S00

Battente MINIMALE
Alluminio: nero
Vetro: sfumato nero

MINIMALE hinged
Aluminium: black
Glass: shaded black

S00

Scorrevole a scomparsa

Alluminio: testa di moro
Vetro: mod. Segni
deco trasparente bronzo
su fondo sabbiato

Pocket sliding

Aluminium: dark brown
Glass: mod. Segni
transparent bronze
decoration on sanded
background





S00

Scorrevole esterno
Alluminio: bianco
Vetro: mod. Viaggio sabbia
deco trasparente su
fondo sabbato

External sliding
Aluminium: white
Glass: mod. Viaggio sabbia
transparent decoration on
sanded background

S00

**Scorrevole esterno muro
binario incassato**
Alluminio: argento
Vetro: mod. Africa
su fondo acidato

*Wall-mounted recessed track
external sliding*
Aluminium: silver
Glass: mod. Africa
on frosted background



S00

**Libro simmetrica
doppia anta**
Alluminio: nero
Vetro: trasparente

*Symmetrical folding
double leaf*
Aluminium: black
Glass: transparent





S00

Battente TRATTO
Alluminio: argento
Vetro: mod. Link
decoro trasparente
su fondo sabbiato

TRATTO hinged
Aluminium: silver
Glass: mod. Link
transparent decoration
on sanded background

SN00

Battente TRATTO
Alluminio: argento
Anta: laccato bianco
ral 9016

TRATTO hinged
Aluminium: silver
Leaf: white lacquered
ral 9016



S00 Scorrevole parallelo interno / Alluminio: nero / Vetro: trasparente
Parallel internal sliding / Aluminium: black / Glass: transparent

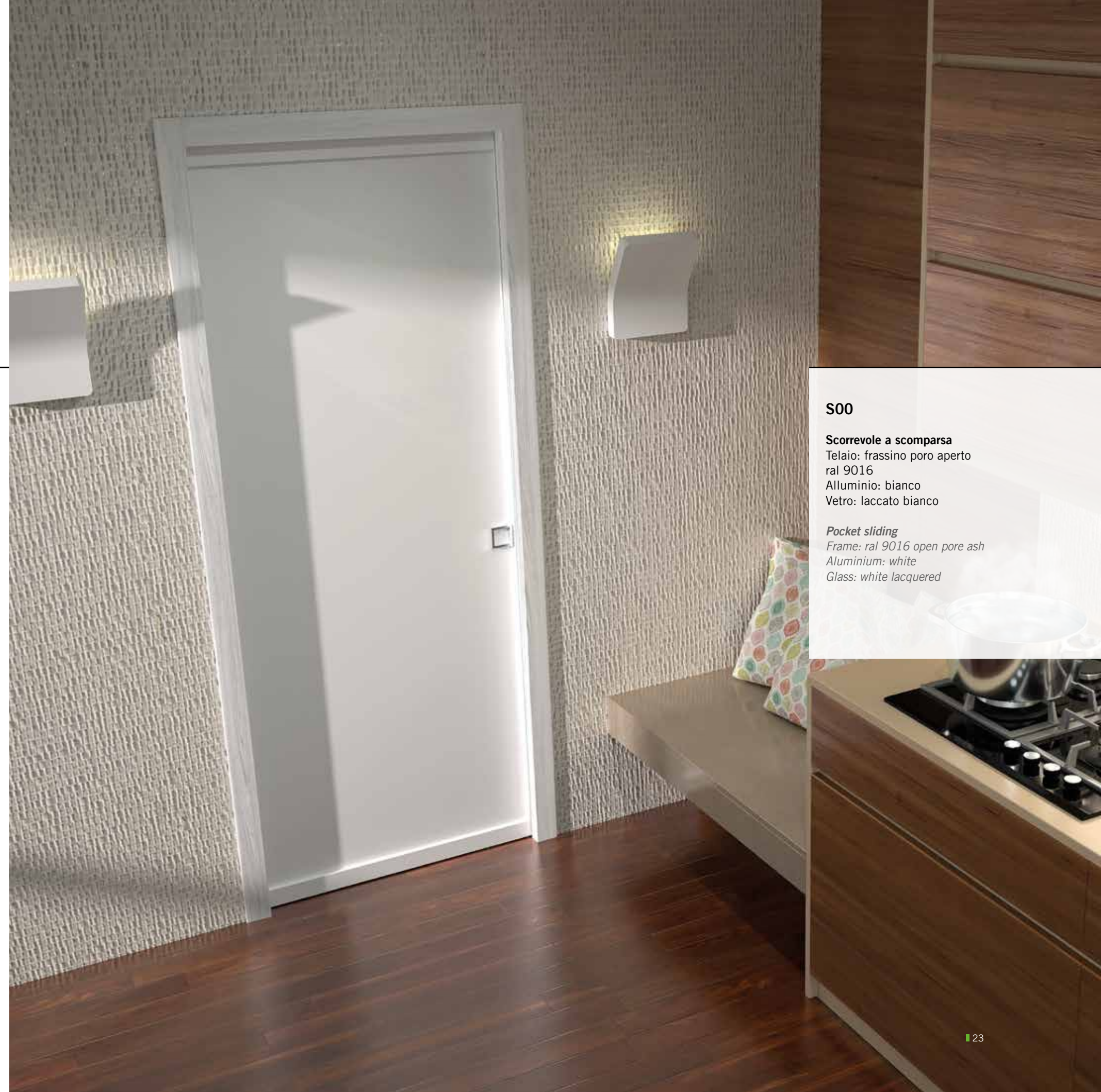

S00

Scorrevole a scomparsa
Telaio: frassino poro aperto
ral 9016
Alluminio: bianco
Vetro: laccato bianco

Pocket sliding
Frame: ral 9016 open pore ash
Aluminium: white
Glass: white lacquered

S00

Battente MINIMALE
Alluminio: argento
Vetro: tessuto bianco

MINIMALE hinged
Aluminium: silver
Glass: white cloth





S00

**Scorrevole esterno
attacco a soffitto**
Alluminio: testa di moro
Vetro: trasparente

Porta NS05
frassino poro aperto ral 9016

*Ceiling mounted
external sliding
Aluminium: dark brown
Glass: transparent*

*Door NS05
ral 9016 open pore ash*



S00

Battente MINIMALE
Alluminio: argento
Vetro: trasparente rosso

MINIMALE hinged
Aluminium: silver
Glass: transparent red

S00

Scorrevole rasomuro
Alluminio: ral 5012
Vetro: stampa digitale
mod. Hippy porpora
su acidato

Rasomuro sliding
Aluminium: ral 5012
Glass: mod. Hippy digital
print purple on frosted





S00

Scorrevole a scomparsa
Alluminio: testa di moro
Vetro: mod. Canne scavo

Pocket sliding
Aluminium: dark brown
Glass: mod. Cane hollow



S00

Battente TRATTO
Alluminio: testa di moro
Vetro: stampa digitale
mod. Gran dama caffè
su acidato

TRATTO hinged
Aluminium: dark brown
Glass: mod. Gran dama
coffee digital print on frosted

SN00

Battente

Anta: laccata ral 1019
Telaio: laccato ral 1019

Hinged

Leaf: ral 1019 lacquered
Frame: ral 1019 lacquered

S02

Scorrevole esterna attacco a parete

Mantovana: laccata ral 1019
Bordo anta: argento
2 vetri acidati
1 vetro trasparente

Wall mounted external sliding

ral 1019 lacquered pelmet
Silver leaf edge
2 frosted glasses
1 transparent glass



S00 Scorrevole esterno binario incassato / Alluminio: nero / Vetro: laccato nero lucido
Recessed track external sliding / Aluminium: black / Glass: glossy black lacquered



S00
Scorrevole rasomuro
 Alluminio: argento
 Vetro: acidato extra chiaro
Rasomuro sliding
 Aluminium: silver
 Glass: extra clear frosted



S00

Battente TRATTO
Alluminio: bianco
Vetro: mod. Tratto
nero su acidato

TRATTO hinged
Aluminium: white
Glass: mod. Tratto
black on frosted

S00

Battente MINIMALE

Alluminio: argento
Vetro: mod. Anthea
doppia sabbatura
trasparente grigio

MINIMALE hinged
Aluminium: silver
Glass: mod. Anthea
double grey transparent
sandblasting





S00

Scorrevole rasomuro
Alluminio: testa di moro
Vetro: mod. Fiori
decoro trasparente
su fondo sabbiato

Rasomuro sliding
Aluminium: dark brown
Glass: mod. Fiori
transparent decoration
on sanded background

S10

**Scorrevole parallelo
interno 3 ante**
Alluminio: nero
Vetro: trasparente

*Parallel internal
sliding 3 leafs*
Aluminium: black
Glass: transparent



MONO

DETTAGLI TECNICI TECHNICAL DETAILS

La linea **S-nziale Mono** è realizzata con un singolo vetro temperato, è disponibile nella versione stratificata con lo spessore di 4+4 mm o su lastra monolitica con lo spessore di 8 mm. In entrambi i casi la struttura è realizzata in alluminio anodizzato o verniciato, con una sezione di 40x16 mm (44x40 mm per i soli traversi orizzontali su porte scorrevoli).

The S-nziale Mono line is made of a single tempered glass, available in the layered version with 4+4 mm thickness or on a single slab with 8 mm thickness. In both cases, the frame is made of anodised or painted aluminium, with a 40x16 mm section (44x40 mm for the sole horizontal beams on sliding doors).

MODELLI

MODELS

- 1. S00
S00
- 2. S01
S01
- 3. S02
S02
- 4. S03
S03
- 5. S04
S04
- 6. S06
S06
- 7. S08
S08
- 8. S10
S10

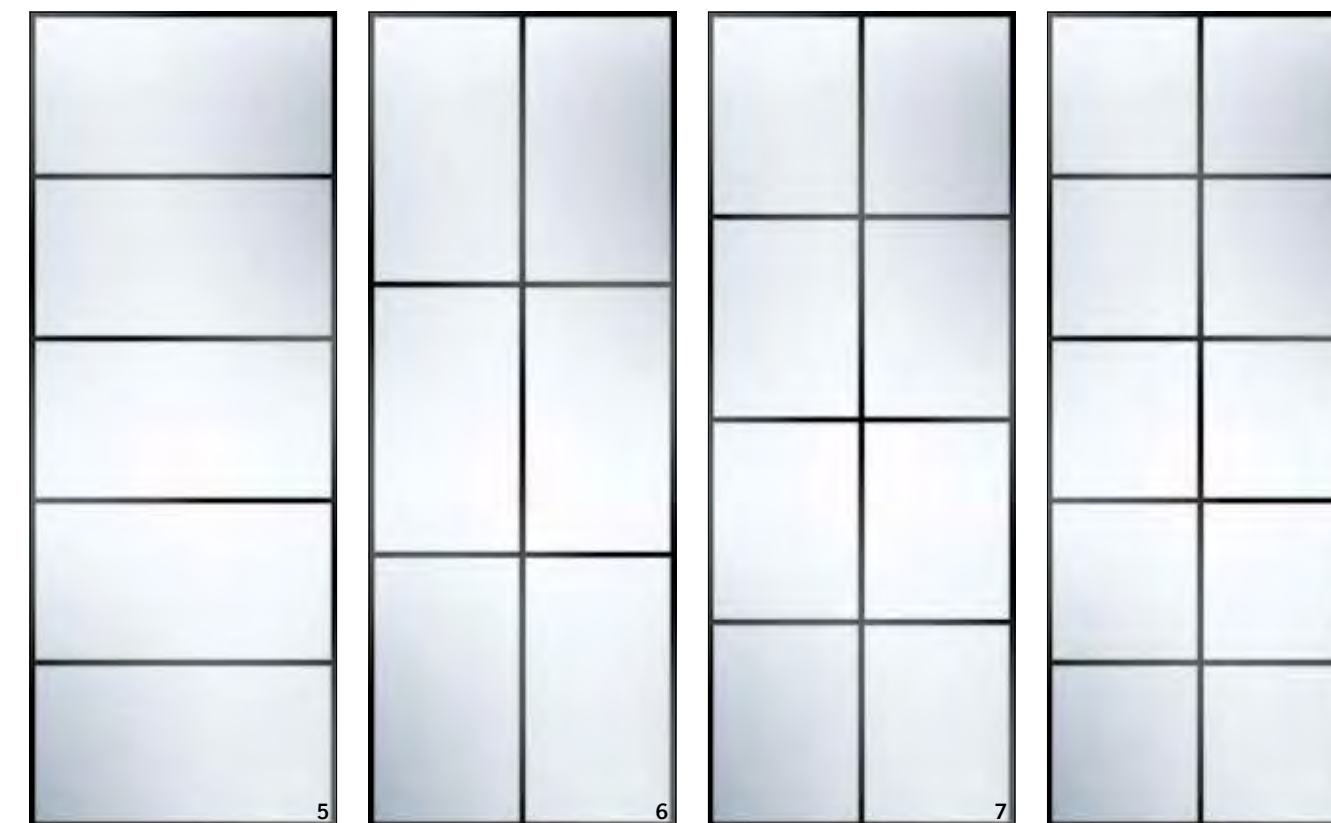
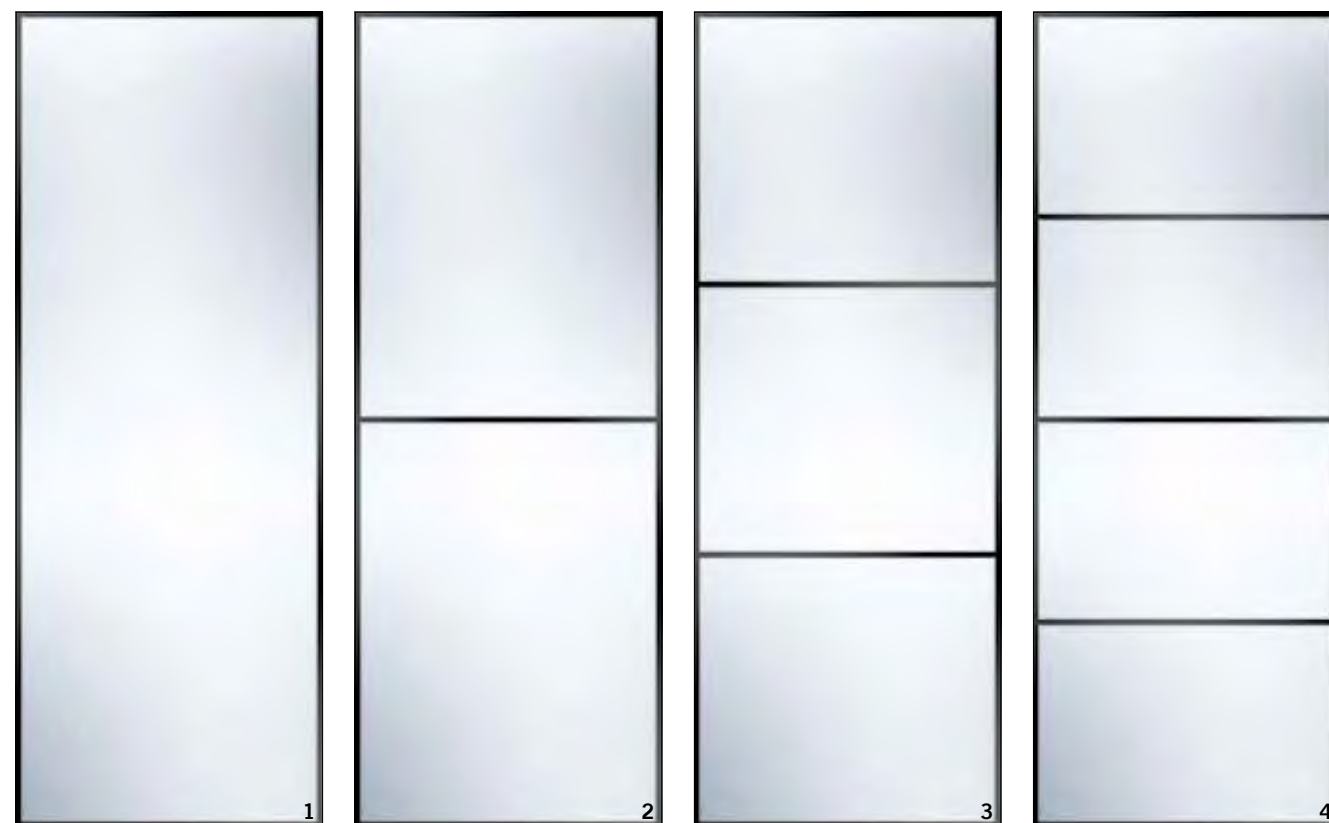

FINITURE

FINISHES

ALLUMINIO ALUMINIUM

1. Argento
Silver
2. Bianco
White
3. Nero
Black
4. Testa di moro
Dark brown

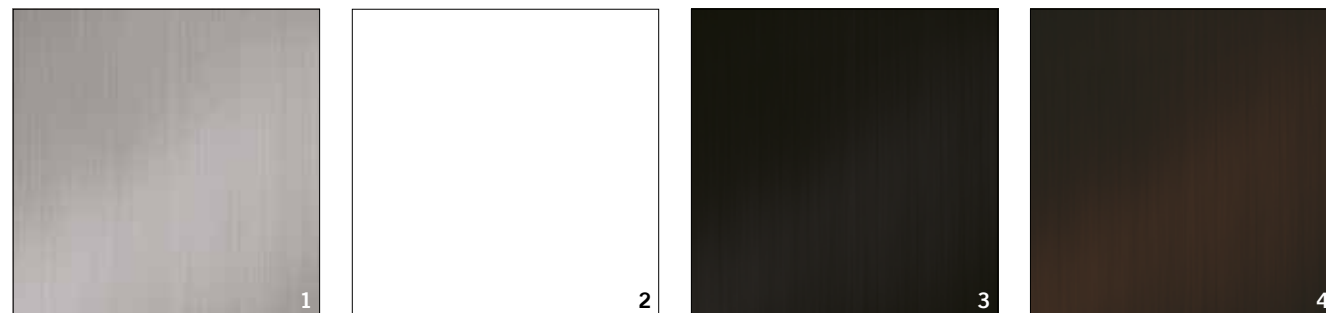

VETRI TRASPARENTI TRANSPARENT GLASS

1. Trasparente
Transparent
2. Trasparente extra chiaro
Extra clear transparent
3. Trasparente bronzo
Transparent bronze
4. Trasparente grigio
Transparent grey
5. Trasparente arancio
Transparent orange
6. Trasparente porpora
Transparent purple
7. Trasparente rosso
Transparent red
8. Trasparente blu
Transparent blue
9. Semiriflettente grigio
Semi-reflective grey

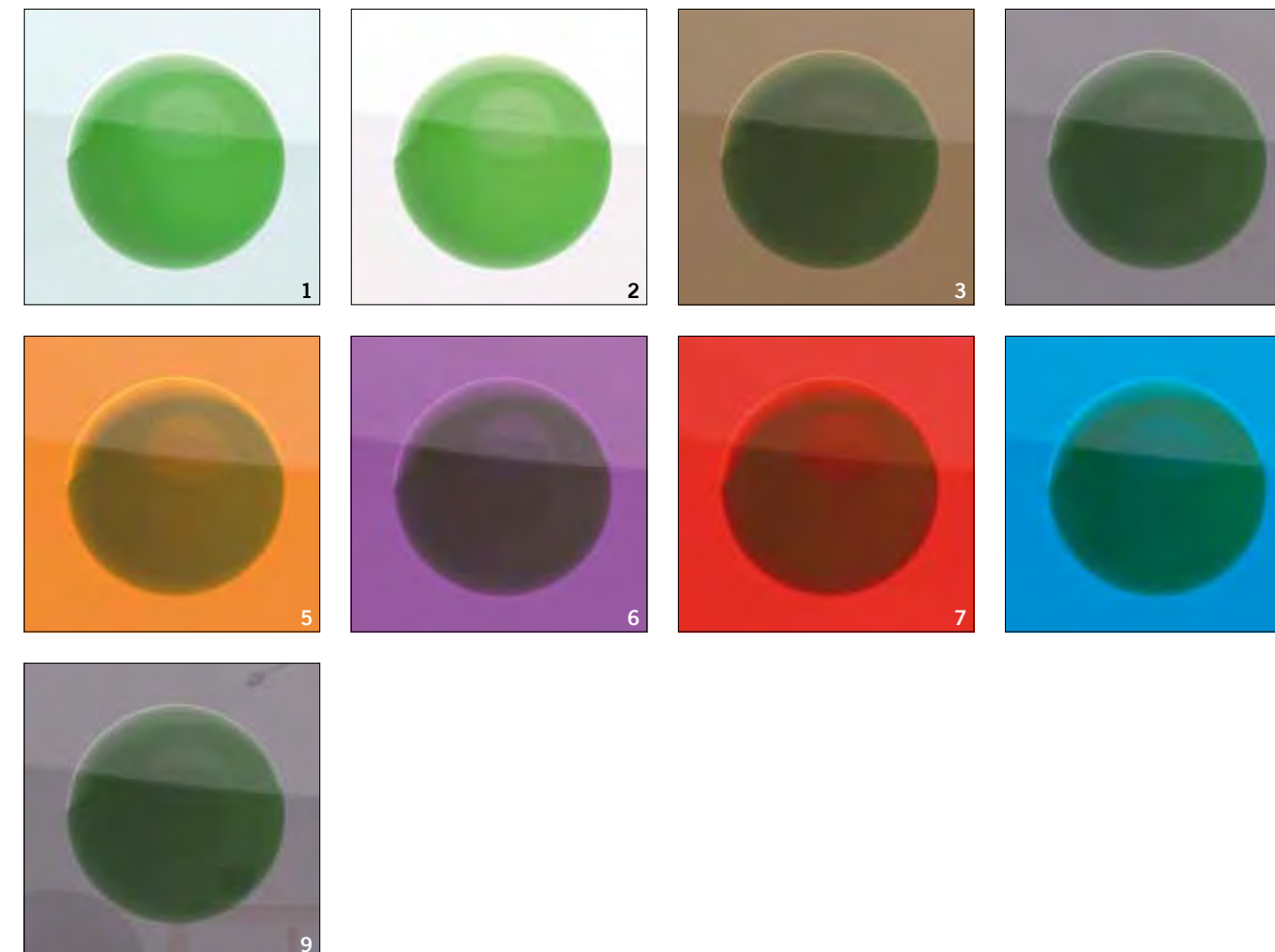

VETRI ACIDATI
FROSTED GLASS

1. Acidato
Frosted
2. Acidato extra chiaro
Extra clear frosted
3. Acidato bronzo
Frosted bronze
4. Acidato grigio
Frosted grey
5. Acidato arancio
Frosted orange
6. Acidato porpora
Frosted purple
7. Acidato rosso
Frosted red
8. Acidato blu
Frosted blue

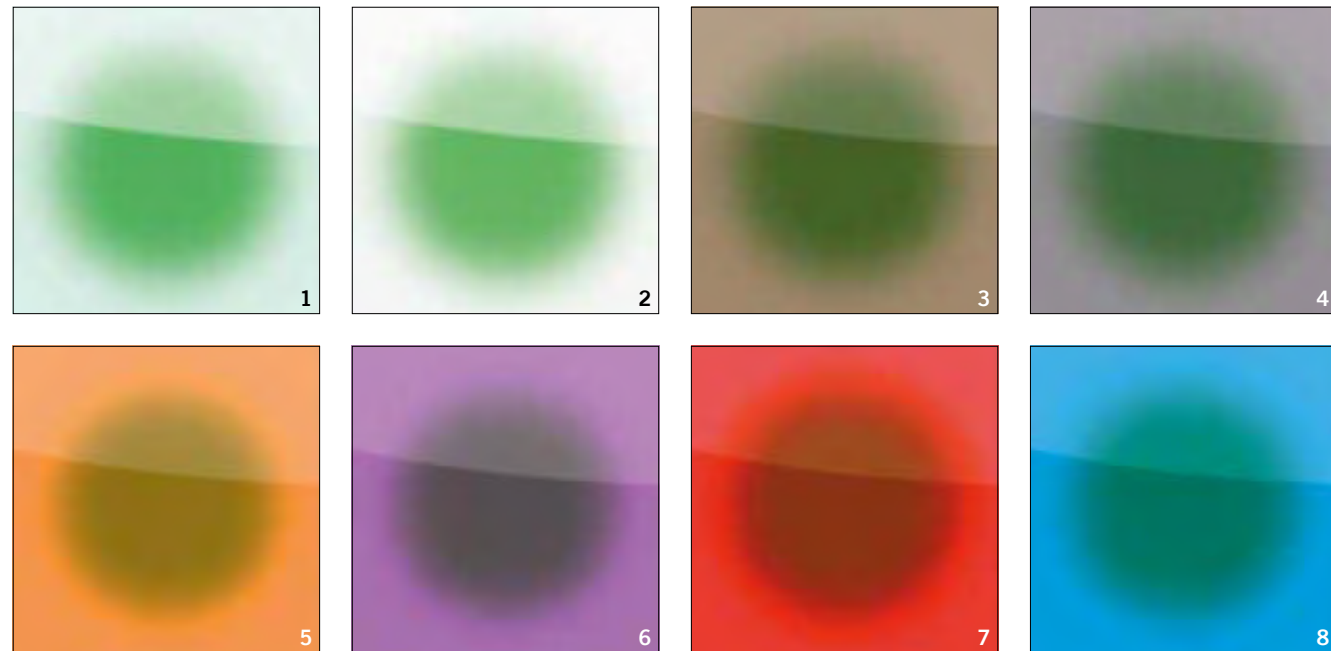

VETRI SFUMATI
SHADED GLASS

1. Sfumato nero
Shaded black
2. Sfumato viola
Shaded violet
3. Sfumato caffè
Shaded coffee
4. Sfumato rosso
Shaded red

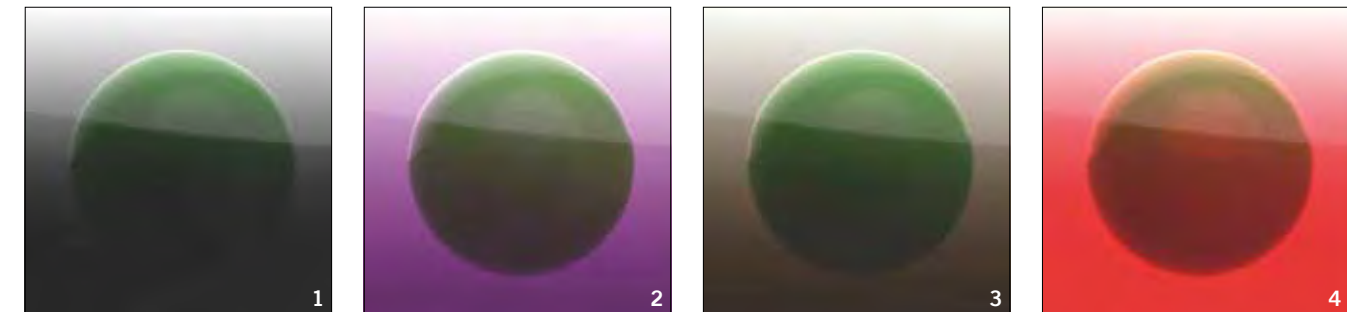

VETRI LACCATI
LACQUERED GLASS

1. Laccato bianco
White lacquered
2. Laccato nero
Black lacquered
3. Laccato rosso
Red lacquered

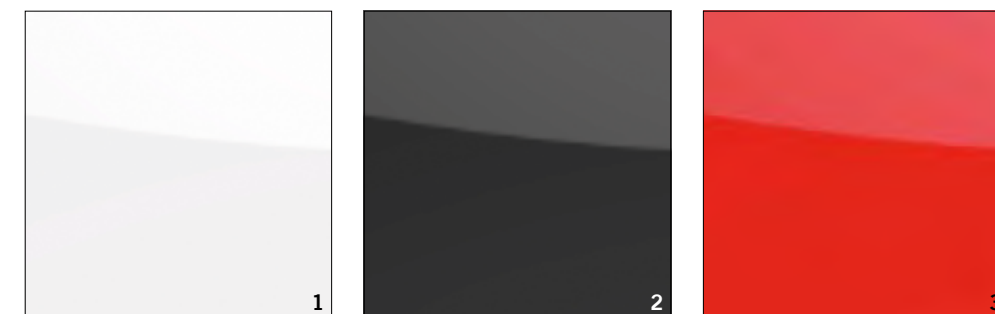

VETRI TESSUTI
CLOTH GLASS

1. Tessuto bianco
White cloth
2. Tessuto nero
Black cloth
3. Tessuto naturale
Natural cloth



VETRI SABBIA
SABBIA GLASS

1. Africa
Africa
2. Messico
Messico
3. Fiori
Fiori
4. Klimt sabbia
Klimt sabbia
5. Viaggio sabbia
Viaggio sabbia
6. Gran dama
Gran dama
7. Hippy
Hippy
8. Link
Link
9. Tela
Tela
10. Segni
Segni
11. Albero sabbia
Albero sabbia
12. Albero sabbia
seconda anta
*Albero sabbia
second leaf*

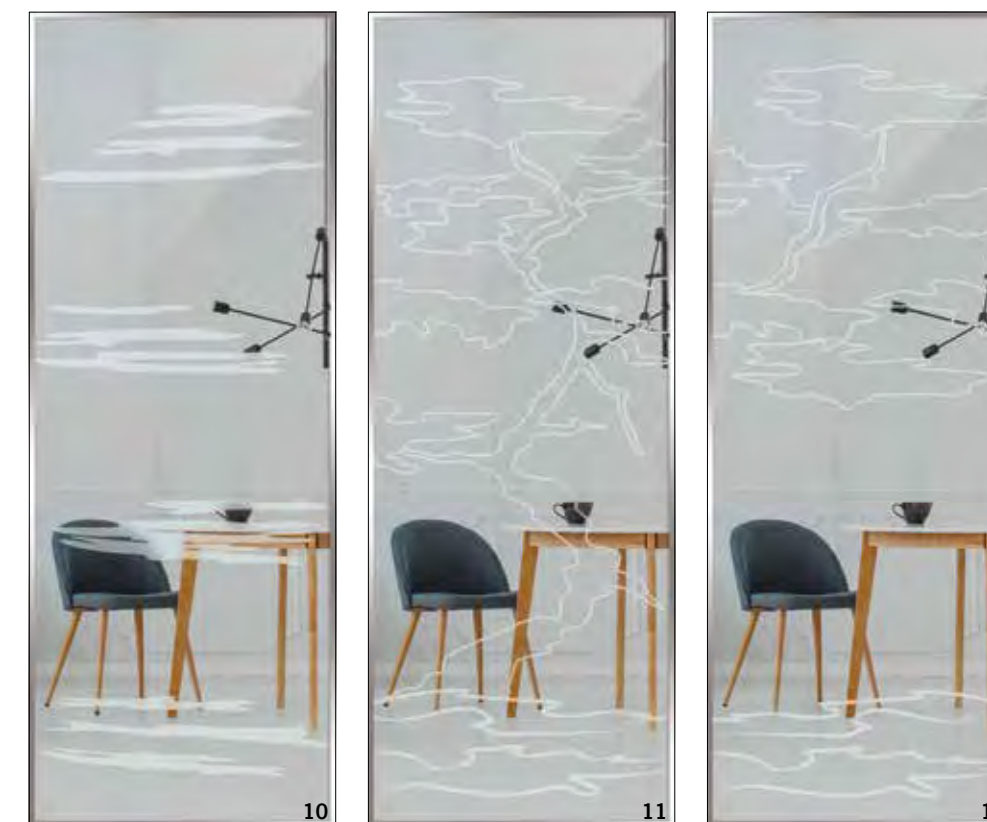
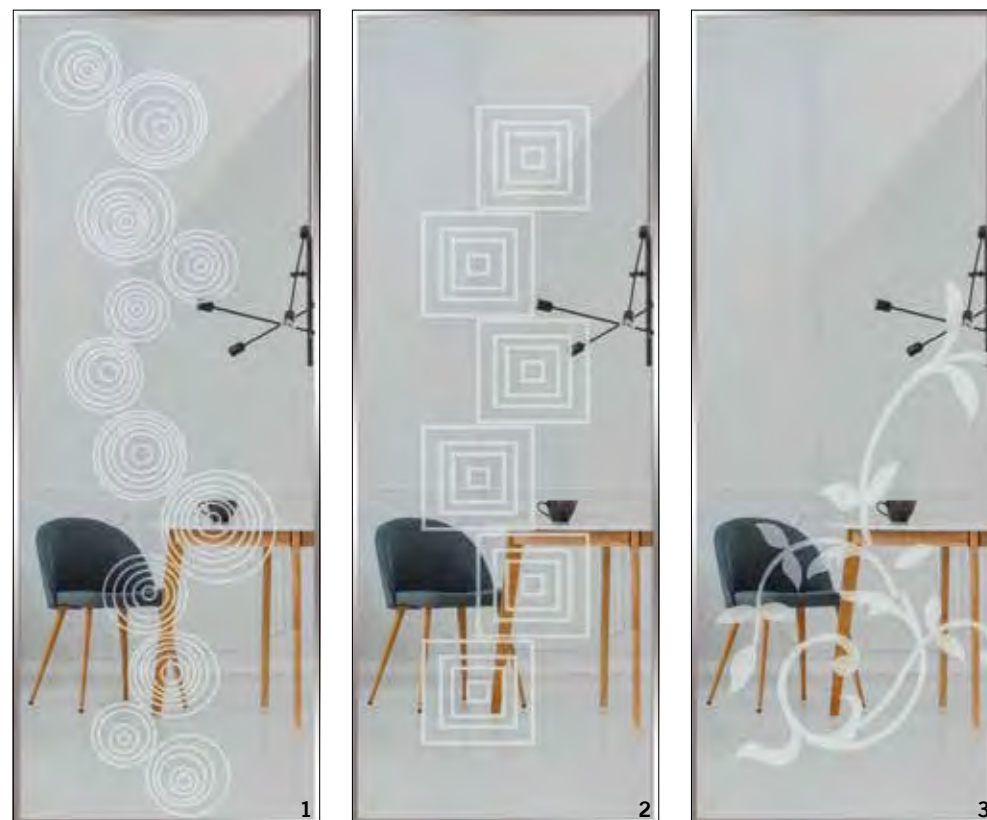

VETRI SCAVO
HOLLOW GLASS

1. Canne
Canne
2. Oriente
Oriente
3. Klimt
Klimt
4. Viaggio
Viaggio
5. Albero
Albero
6. Albero seconda anta
Albero second leaf



VETRI STAMPA DIGITALE
DIGITAL PRINT
GLASS

1. Anthea
Anthea
2. Abstract
Abstract
3. Capitali
Capitali
4. Gran dama (6 colori)
Gran dama (6 colours)
5. Hippy (6 colori)
Hippy (6 colours)
6. Mondrian
Mondrian



VETRI SABBATI
FLESSYA
FLESSYA SANDED
GLASS

- 1. NS00
NS00
- 2. NS05
NS05
- 3. NS08
NS08
- 4. NR00
NR00
- 5. NR13
NR13
- 6. NR20
NR20
- 7. NR30
NR30
- 8. NR31
NR31
- 9. N15
N15
- 10. N15A
N15A
- 11. NF00
NF00
- 12. P31
P31

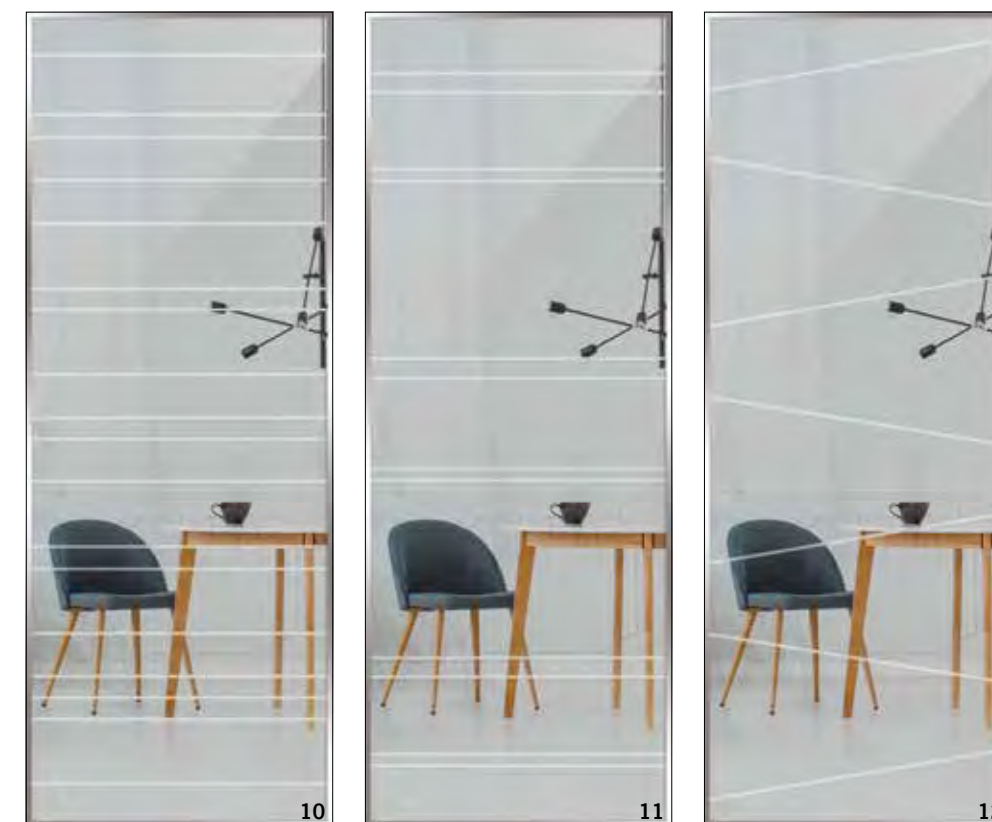
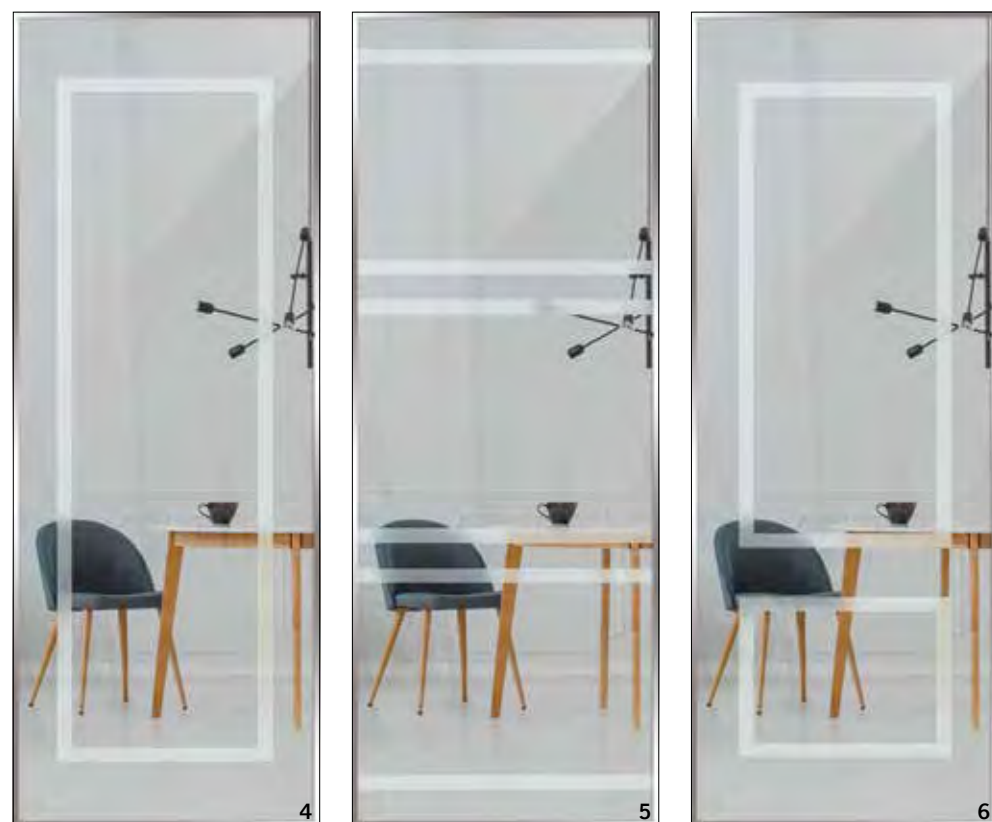
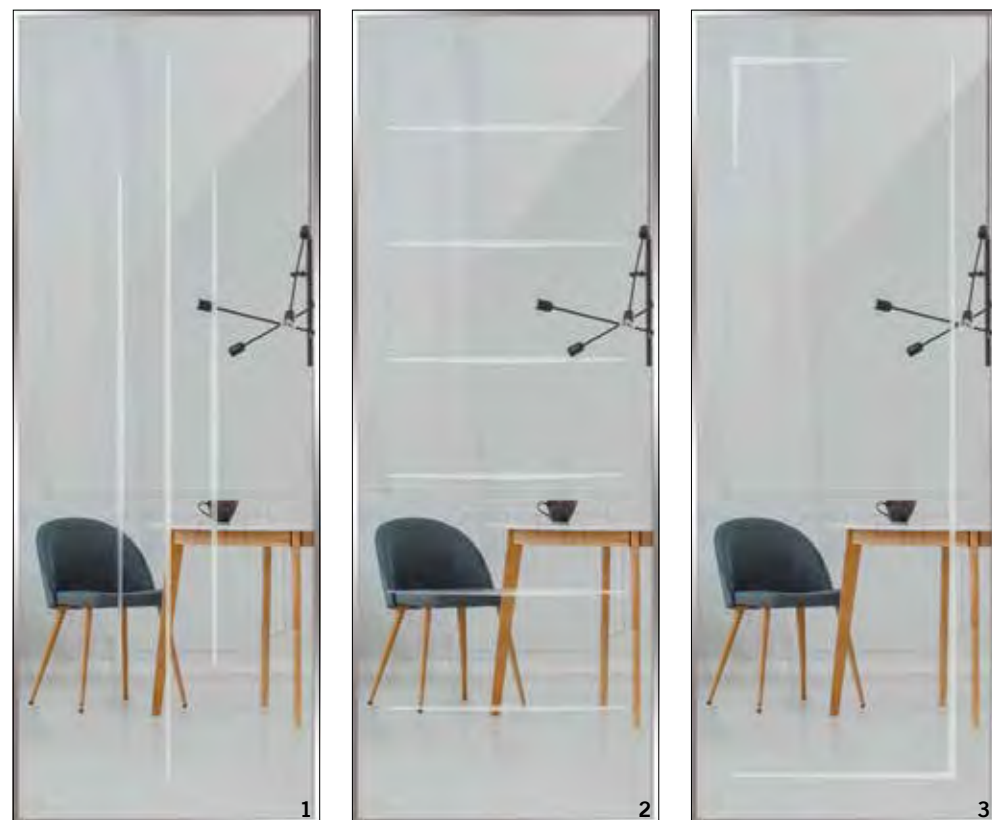

DISEGNI TECNICI / Battenti

TECHNICAL DRAWS / Hinged

TRATTO

Porta battente per muro con controtelaio in legno
Hinged door for wall with wooden counter-frame

- A. Anta singola
Single leaf
- B. Anta doppia
Double leaf

- H Luce netta passaggio
Net passage clearance
- H1 Esterno telaio
External frame
- H2 Interno controtelaio
Internal counter-frame
- H3 Esterno cornice
External moulding
- L Luce netta passaggio
Net passage clearance
- L1 Esterno telaio
External frame
- L2 Interno controtelaio
Internal counter-frame
- L3 Esterno cornice
External moulding

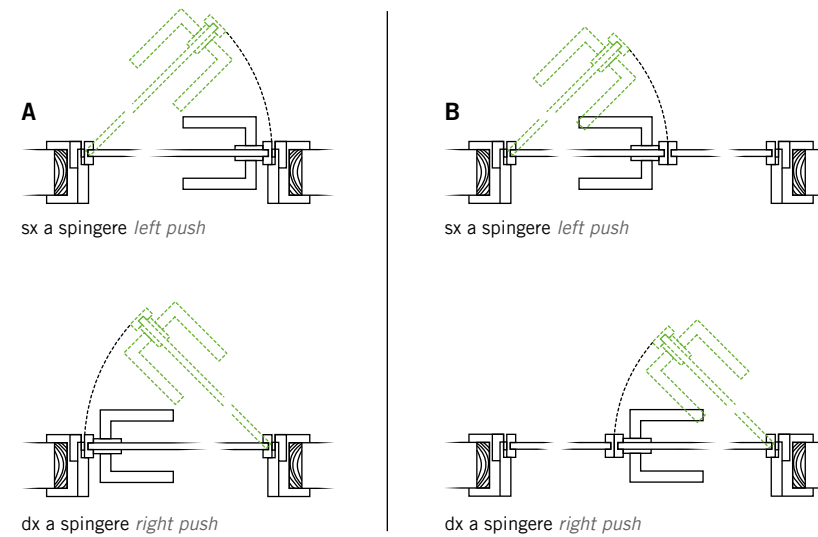
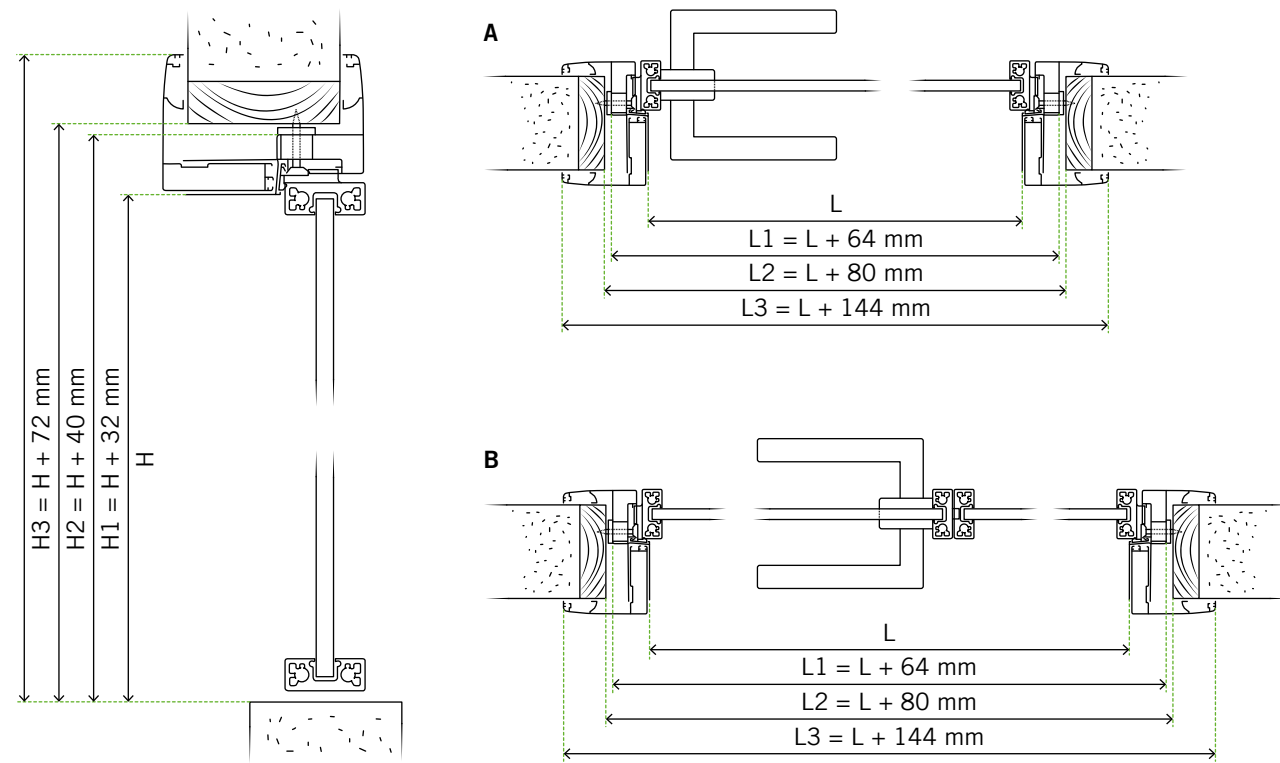

MINIMALE

Porta battente per muro finito
Hinged door for finished wall

- A. Anta singola
Single leaf
- B. Anta doppia
Double leaf

- H Luce netta passaggio
Net passage clearance
- H1 Esterno telaio
External frame
- H2 Interno controtelaio
Internal counter-frame
- L Luce netta passaggio
Net passage clearance
- L1 Esterno telaio
External frame
- L2 Interno controtelaio
Internal counter-frame

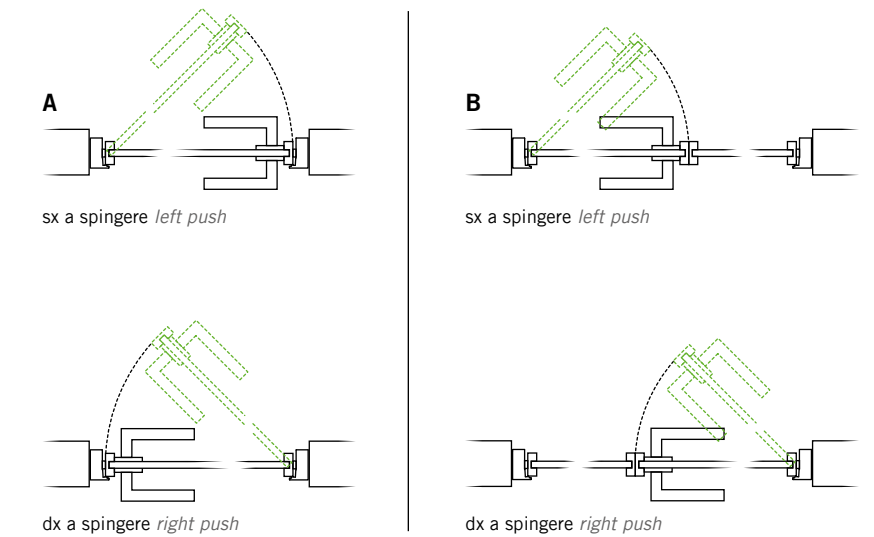
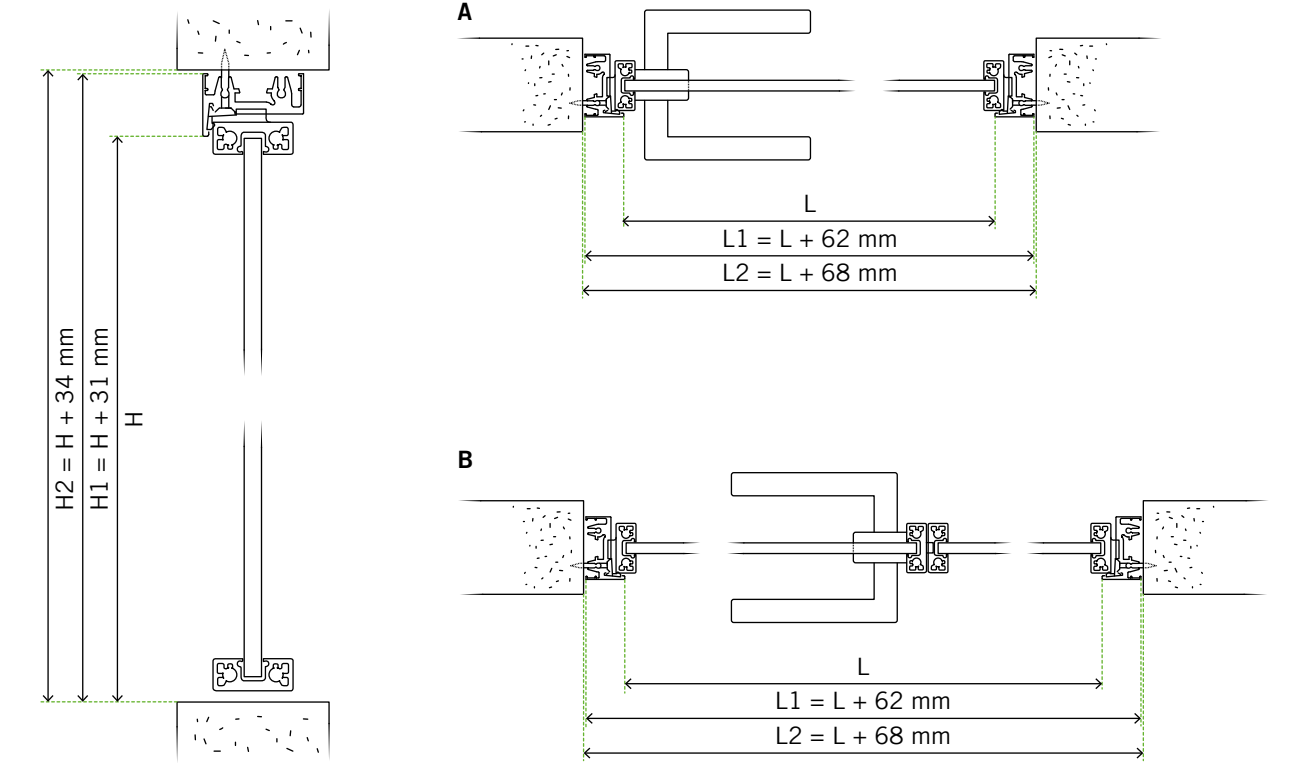

DISEGNI TECNICI / Scorrevoli a scomparsa

TECHNICAL DRAWS / Pocket sliding

TRATTO

Porta scorrevole a scomparsa
Pocket sliding door

- A. Anta singola
Single leaf
- B. Anta doppia
Double leaf

- H Luce netta passaggio
Net passage clearance
- H1 Esterno telaio
External frame
- H2 Esterno cornice
External moulding
- L Luce netta passaggio
Net passage clearance
- L1 Esterno telaio
External frame
- L2 Esterno cornice
External moulding

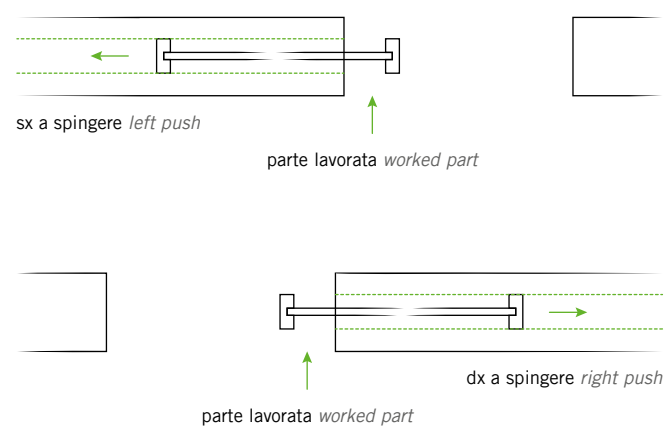
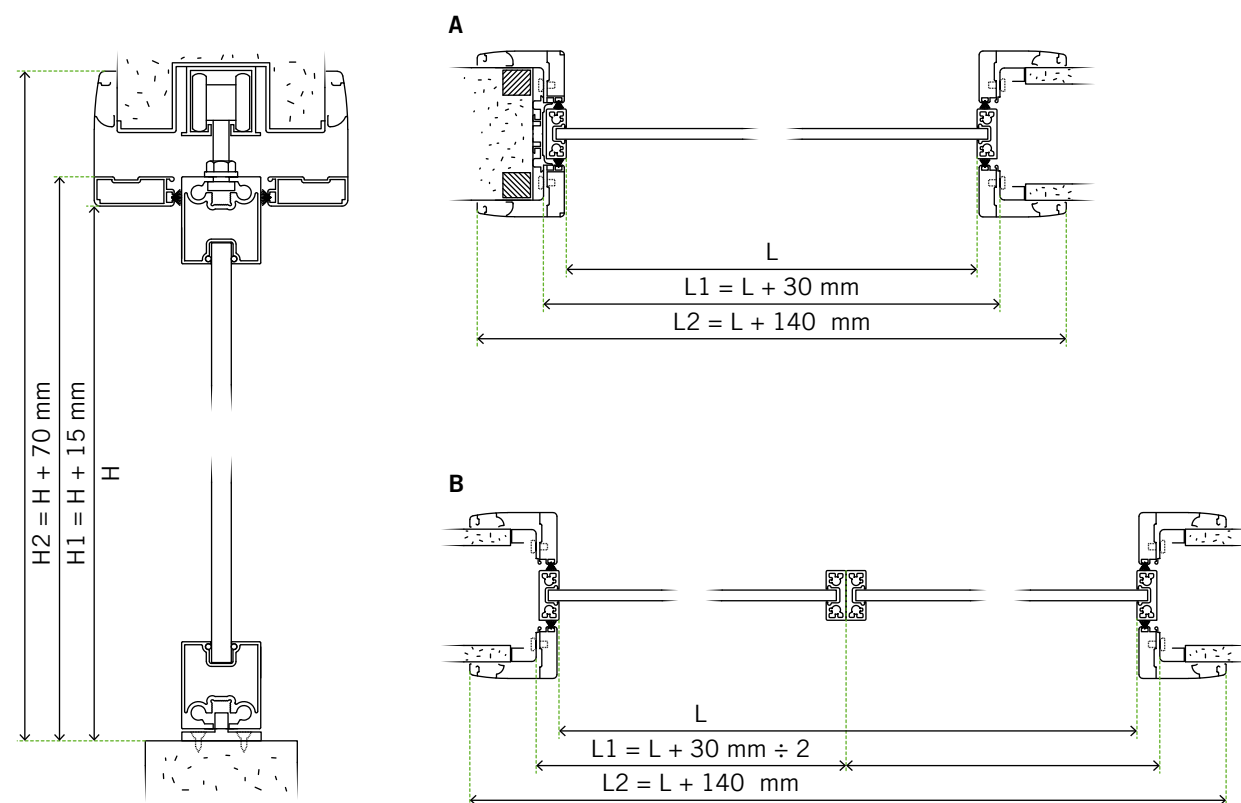

RASOMURO

Porta scorrevole a scomparsa
senza telaio
Pocket sliding door
without frame

- A. Anta singola
Single leaf
- B. Anta doppia
Double leaf

- H Luce netta passaggio
Net passage clearance
- H1 Anta finita
Finished leaf
- L Luce netta passaggio
Net passage clearance
- L1 Anta finita
Finished leaf

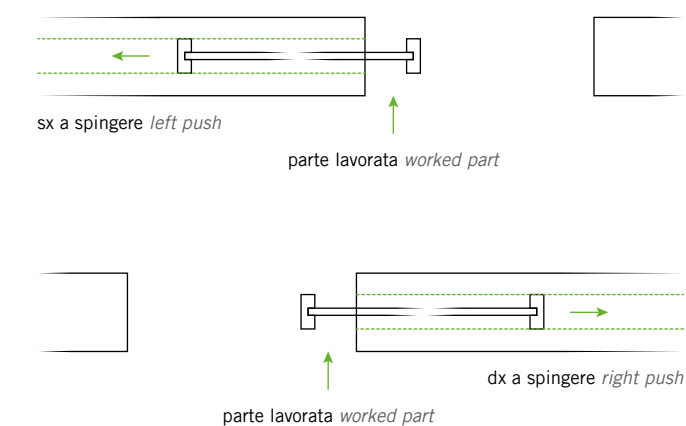
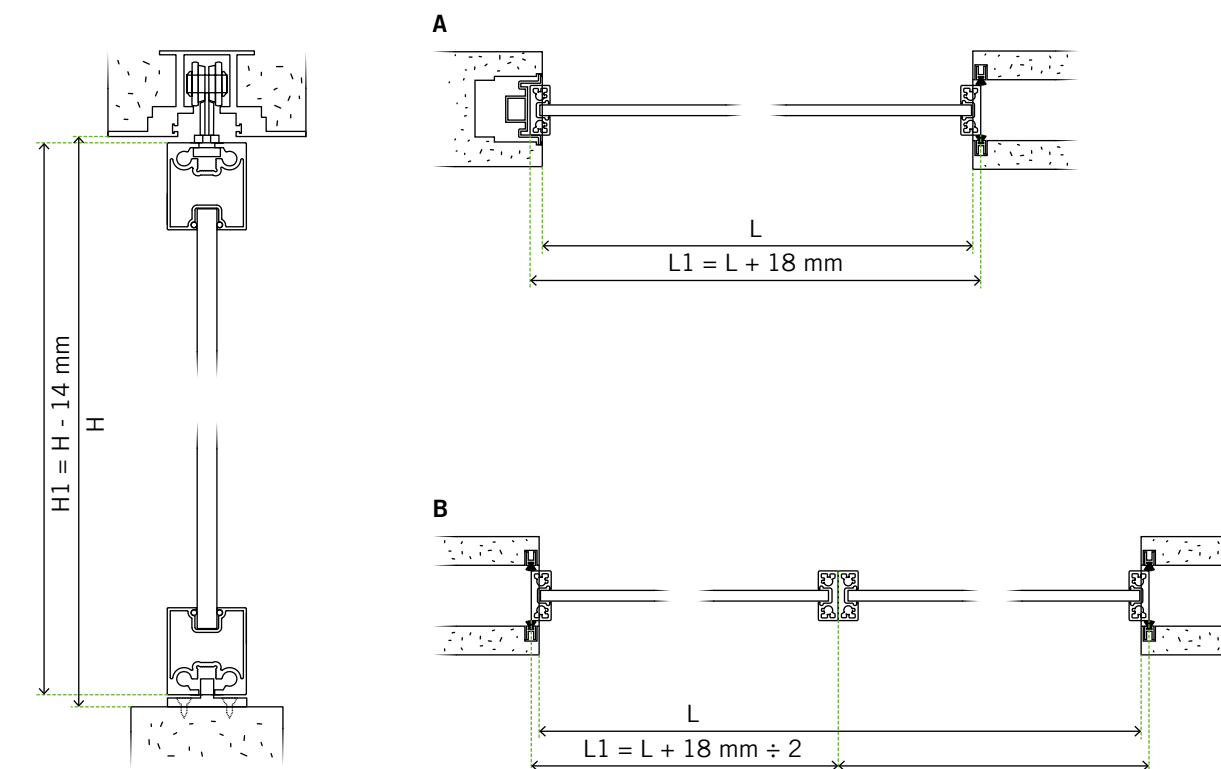

DISEGNI TECNICI / Scorrevoli esterni

TECNICAL DRAWS / External sliding

Porta scorrevole esterno
External sliding door

1. **Binario incassato**
Recessed track
2. **Attacco a soffitto**
Ceiling mount
3. **Attacco a parete**
Wall mount

- A. **Anta singola**
Single leaf
- B. **Anta doppia**
Double leaf

- H Luce netta passaggio
Net passage clearance
- H1 Anta finita
Finished leaf
- L Luce netta passaggio
Net passage clearance
- L1 Anta finita
Finished leaf

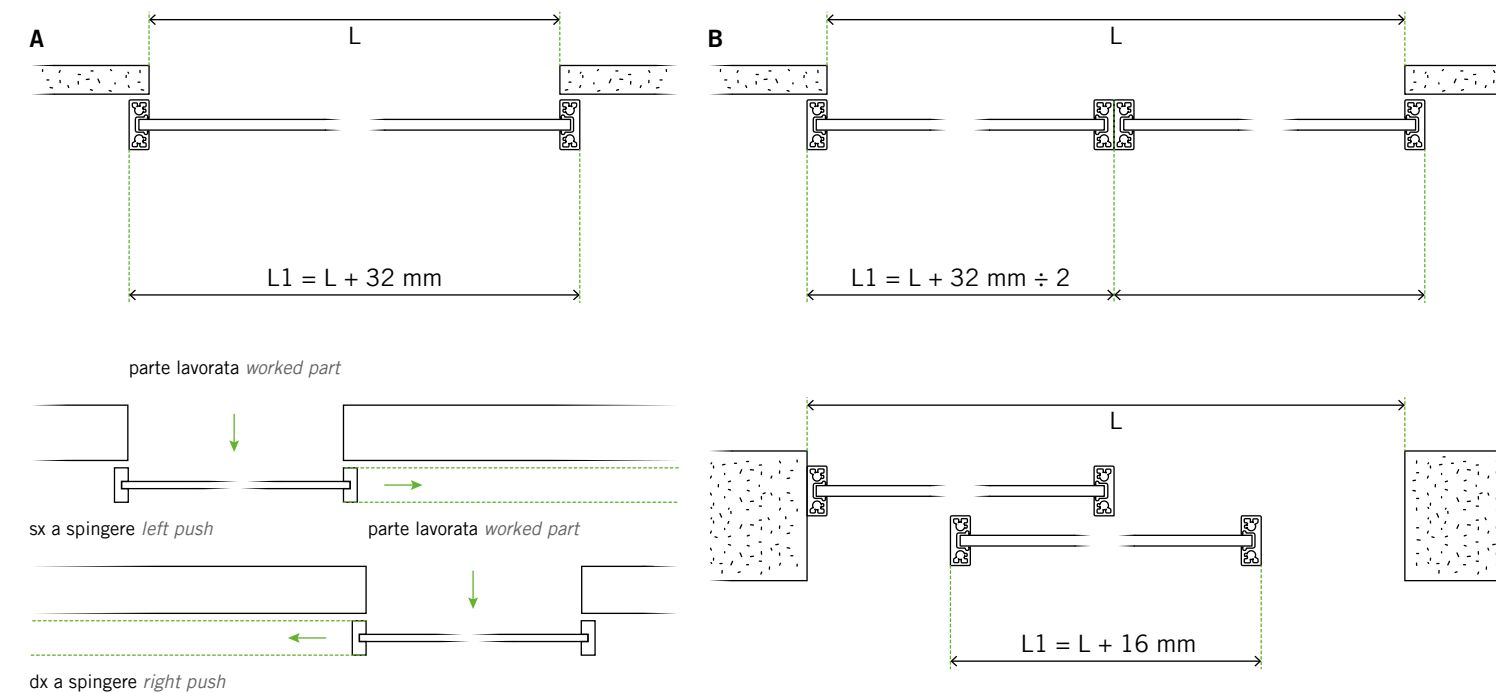
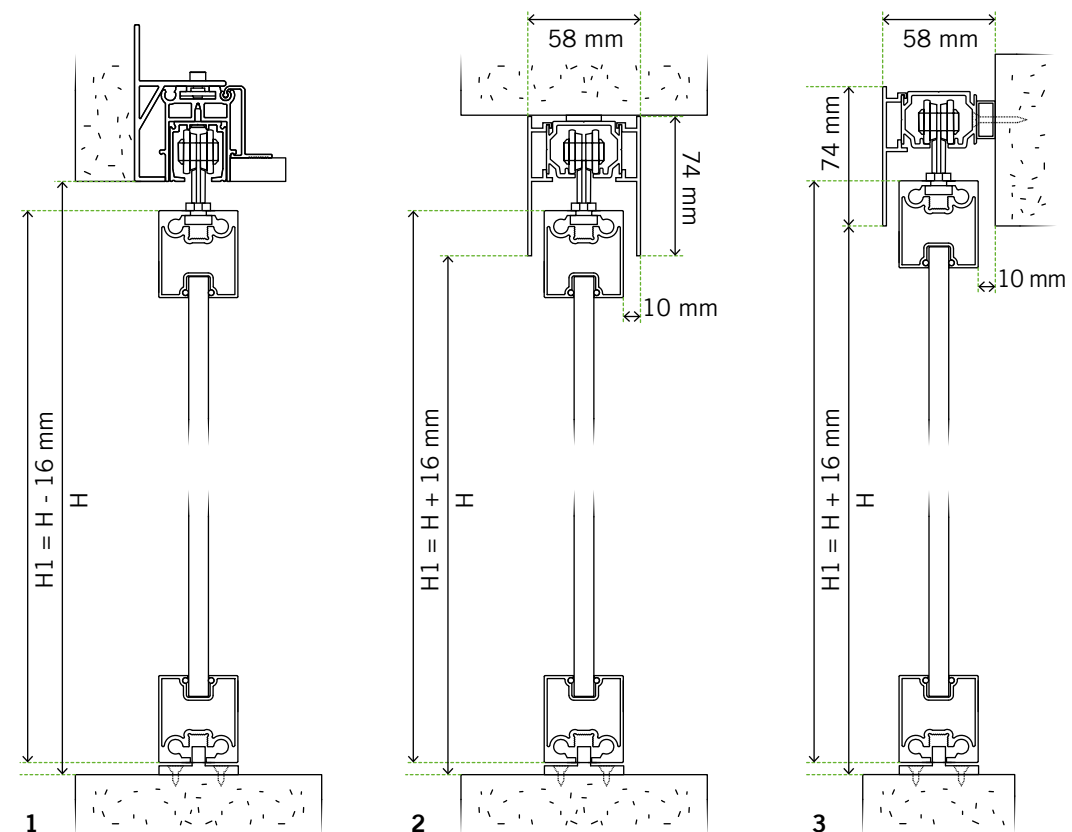

MANIGLIE / Battenti

HANDLES / Hinged door

1. Mira foro patent
Mira patent hole
2. Mira con nottolino
Mira with knob
3. Mira con cilindro yale
Mira with yale cylinder
4. Quadra foro patent
Quadra patent hole
5. Quadra con nottolino
Quadra with knob
6. Quadra con cilindro yale
Quadra with yale cylinder



MANIGLIE / Scorrevoli

HANDLES / Sliding door

1. Rettangolare
acciaio inox 64x150 mm
*Regular stainless steel
64x150 mm*
2. Quadrata
acciaio inox 64x64 mm
*Square stainless steel
64x64 mm*
3. A 'C' argento
172 mm o 332 mm
*'C' silver 172 mm
or 332 mm*
4. A 'L' argento
o in tutte le finiture
140 mm, 500 mm
o 1000 mm
*'L' silver or in all finishes
140 mm, 500 mm
or 1000 mm*
5. Kit di chiusura
per scorrevole
lato interno argento
*Internal side sliding
silver closure kit*
6. Kit di chiusura
per scorrevole
lato esterno argento
*External side sliding
silver closure kit*

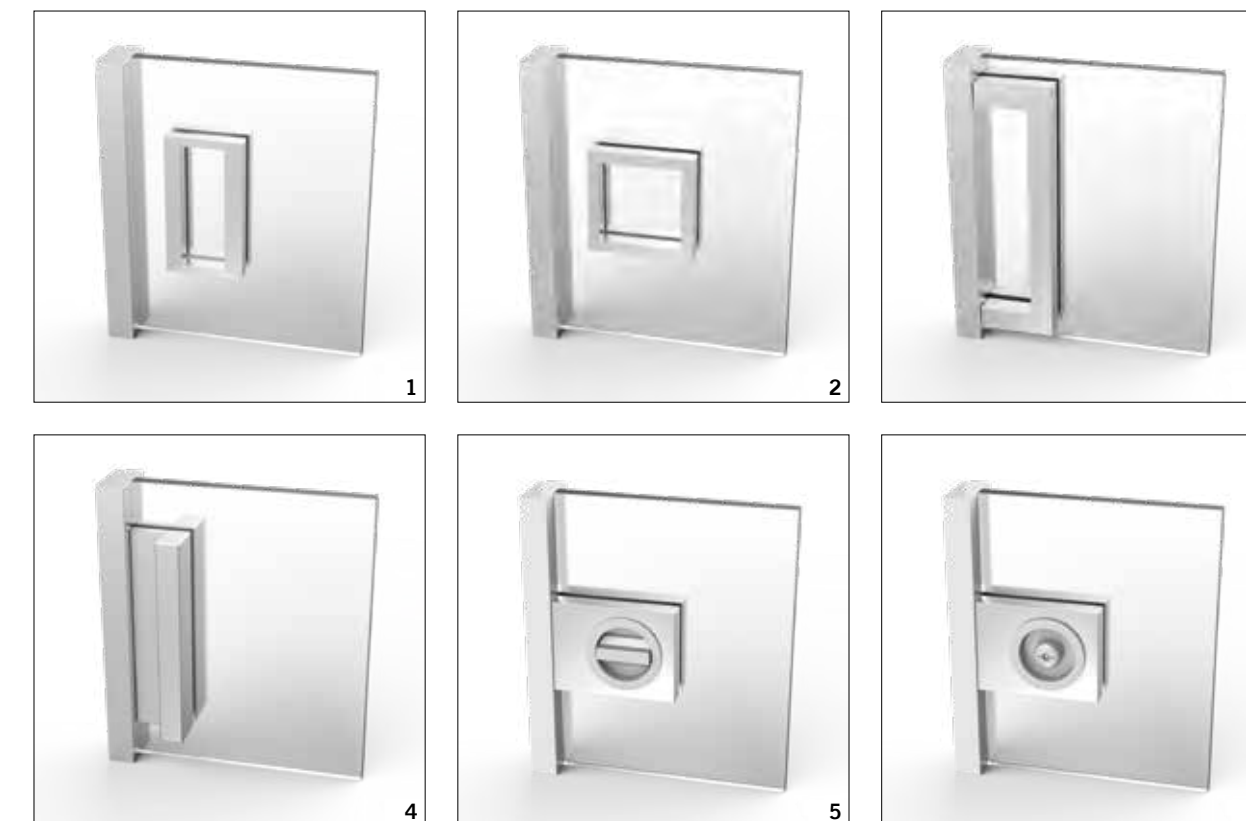

D U O

Due, come i vetri che si uniscono per raddoppiare la materialità. L'armonia nata dal contrasto tra forza e leggerezza, che riesce a rendere semplice anche ciò che si presenta come eccezionale. Con **S-nziale Duo** la superficie diventa più importante amplificando la sua eleganza e la sua semplicità.

*Two, like the glass that combine to double the matter. The harmony that emerges from the contrast between strength and levity, that can even make something that seems exceptional, simple. With **S-nziale Duo**, the surface becomes more important, intensifying its elegance and simplicity.*



SD00

Battente TRATTO
Alluminio: bianco
Vetro: acidato extra chiaro

TRATTO hinged
Aluminium: white
Glass: extra clear frosted

SD00

Scorrevole rasomuro
Alluminio: nero
Vetro: trasparente grigio

Rasomuro sliding
Aluminium: black
Glass: transparent grey





SD00

**Libro asimmetrica 3 ante
con anta fissa laterale**
Alluminio: argento
Vetro: trasparente e
laccato ral 1019

*Asymmetrical folding 3 leaves
with fixed side leaf*
Aluminium: silver
Glass: transparent and
lacquered ral 1019



SD00

Scorrevole parallelo interno
Alluminio: argento
Vetro: trasparente
grigio semiriflettente

Parallel internal sliding
Aluminium: silver
Glass: semi-reflective
transparent grey

SD00

Battente TRATTO
Alluminio: argento
Vetro: laccato bianco

TRATTO hinged
Aluminium: silver
Glass: white lacquered





SD00

Battente TRATTO
Alluminio: argento
Vetro: acidato

TRATTO hinged
Aluminium: silver
Glass: frosted

SD00

Scorrevole a scomparsa
Alluminio: argento
Vetro: acidato

Pocket sliding
Aluminium: silver
Glass: frosted

SD00

**Scorrevole esterno
attacco a soffitto**
Alluminio: bianco
Vetro: specchio

*Ceiling mounted
external sliding*
Aluminium: white
Glass: mirror





SD00

Battente MINIMAL
Alluminio: argento
Vetro: acidato

MINIMAL hinged
Aluminium: silver
Glass: frosted



SD00 Scorrevole esterno attacco a parete / Alluminio: bianco / Vetro: trasparente
Wall mounted external sliding / Aluminium: white / Glass: transparent

SD00

Scorrevole rasomuro
Alluminio: nero
Vetro: trasparente bronzo

Rasomuro sliding
Aluminium: black
Glass: transparent bronze



SD00

Scorrevole parallelo interno
Alluminio: nero
Vetro: trasparente bronzo

Parallel internal sliding
Aluminium: black
Glass: transparent bronze

D U O

DETTAGLI TECNICI TECHNICAL DETAILS

La linea **S-nziale Duo** è realizzata con una coppia di vetri temperati, fissati su un telaio in alluminio interno all'anta. I vetri monolitici hanno uno spessore di 5 mm e si possono realizzare nella versione trasparente, acidata oppure laccata in vari colori. Il bordo in alluminio a vista è di soli 3 mm ed i vetri acidati vengono serigrafati perimetralmente per nascondere la sottostruttura in alluminio.

*The **S-nziale Duo** line is made with a pair of tempered glasses, secured on an aluminium frame in the leaf. Single slab glass is 5 mm thick and can be made in the transparent or frosted versions or lacquered in various colours. The visible aluminium edge is only 3 mm and frosted glass is silk-screened around the edge to hide the aluminium sub-structure.*

FINITURE

FINISHES

ALLUMINIO ALUMINIUM

1. Argento
Silver
2. Bianco
White
3. Nero
Black
4. Testa di moro
Dark brown



VETRI TRASPARENTI TRANSPARENT GLASS

1. Trasparente
Transparent
2. Trasparente extra chiaro
Extra clear transparent
3. Trasparente bronzo
Transparent bronze
4. Trasparente grigio
Transparent grey
5. Trasparente arancio
Transparent orange
6. Trasparente porpora
Transparent purple
7. Trasparente rosso
Transparent red
8. Trasparente blu
Transparent blue
9. Semiriflettente grigio
Semi-reflective grey

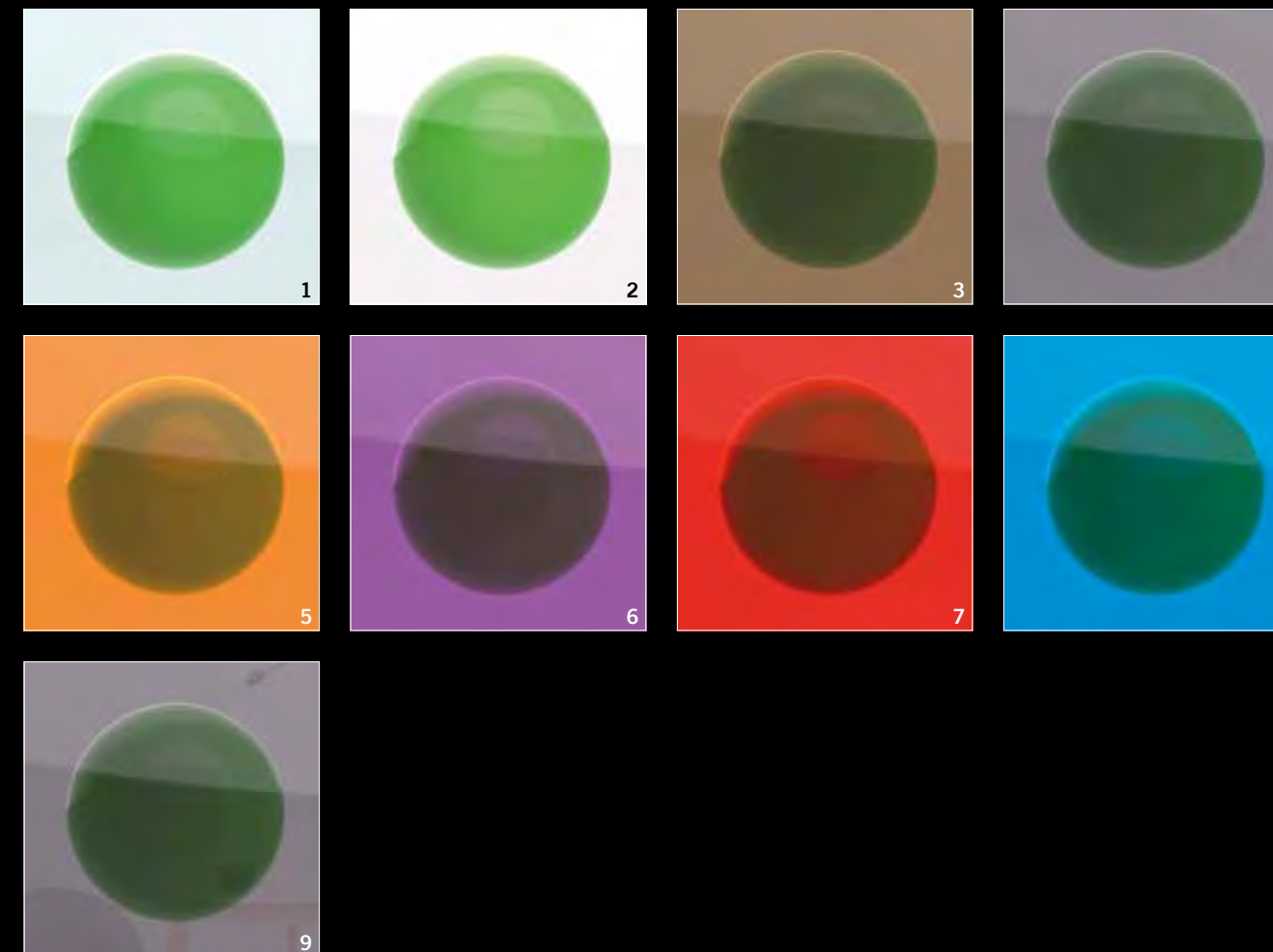

VETRI ACIDATI
FROSTED GLASS

1. Acidato
Frosted
2. Acidato extra chiaro
Extra clear frosted
3. Acidato bronzo
Frosted bronze
4. Acidato grigio
Frosted grey
5. Acidato arancio
Frosted orange
6. Acidato porpora
Frosted purple
7. Acidato rosso
Frosted red
8. Acidato blu
Frosted blue

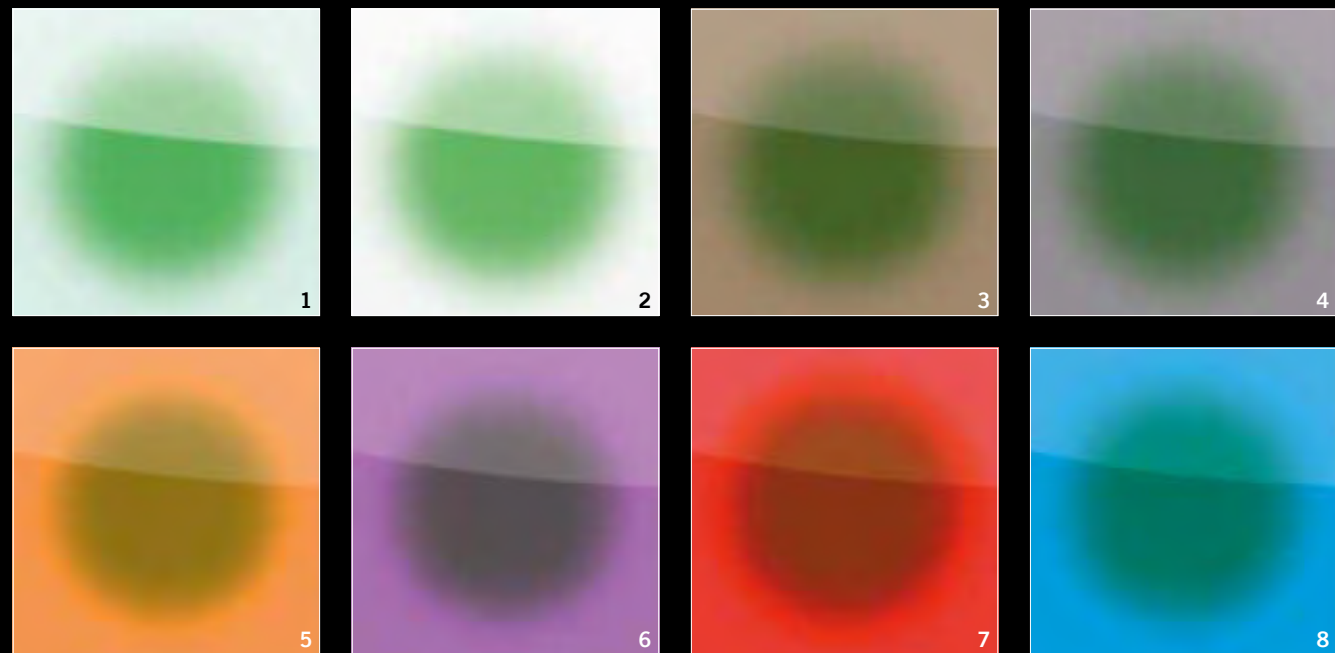

VETRI LACCATI
LACQUERED GLASS

1. Laccato bianco
White lacquered
2. Laccato nero
Black lacquered
3. Laccato rosso
Red lacquered
4. Specchio
Mirror

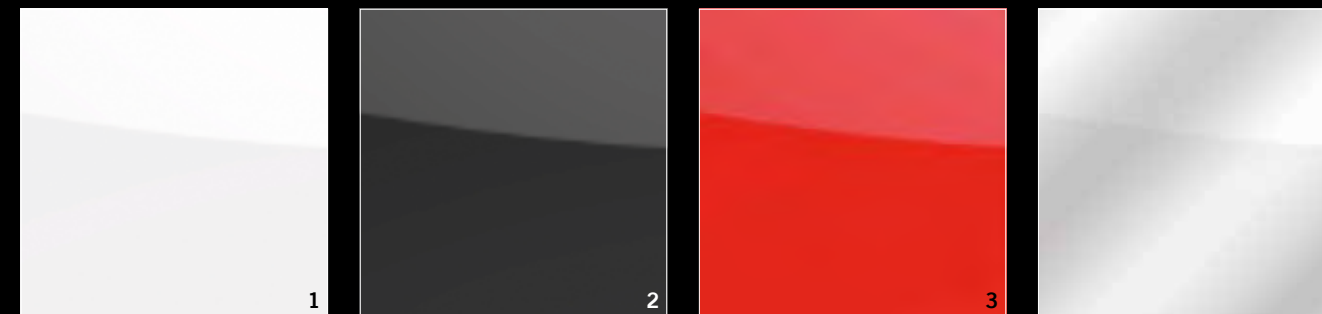

DISEGNI TECNICI / Battenti

TECHNICAL DRAWS / Hinged

TRATTO

Porta battente per muro con controtelaio in legno
Hinged door for wall with wooden counter-frame

- A. Anta singola
Single leaf
- B. Anta doppia
Double leaf

- H Luce netta passaggio
Net passage clearance
- H1 Esterno telaio
External frame
- H2 Interno controtelaio
Internal counter-frame
- H3 Esterno cornice
External moulding
- L Luce netta passaggio
Net passage clearance
- L1 Esterno telaio
External frame
- L2 Interno controtelaio
Internal counter-frame
- L3 Esterno cornice
External moulding

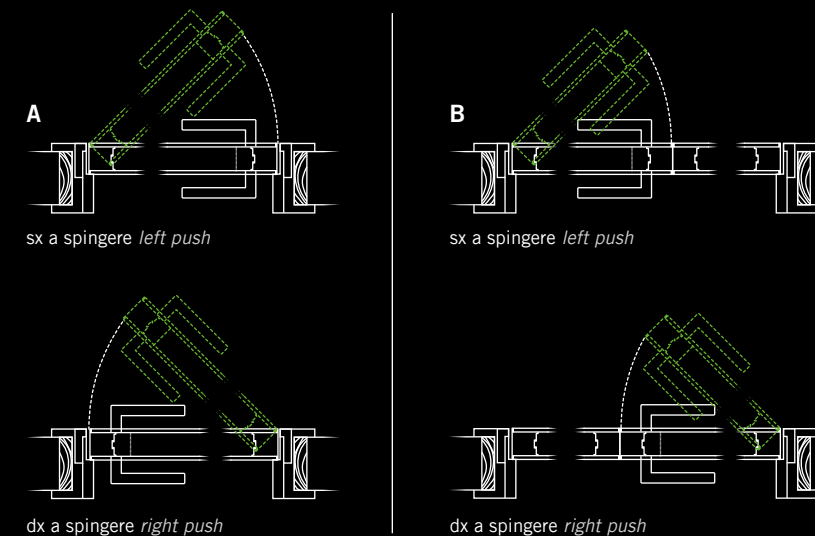
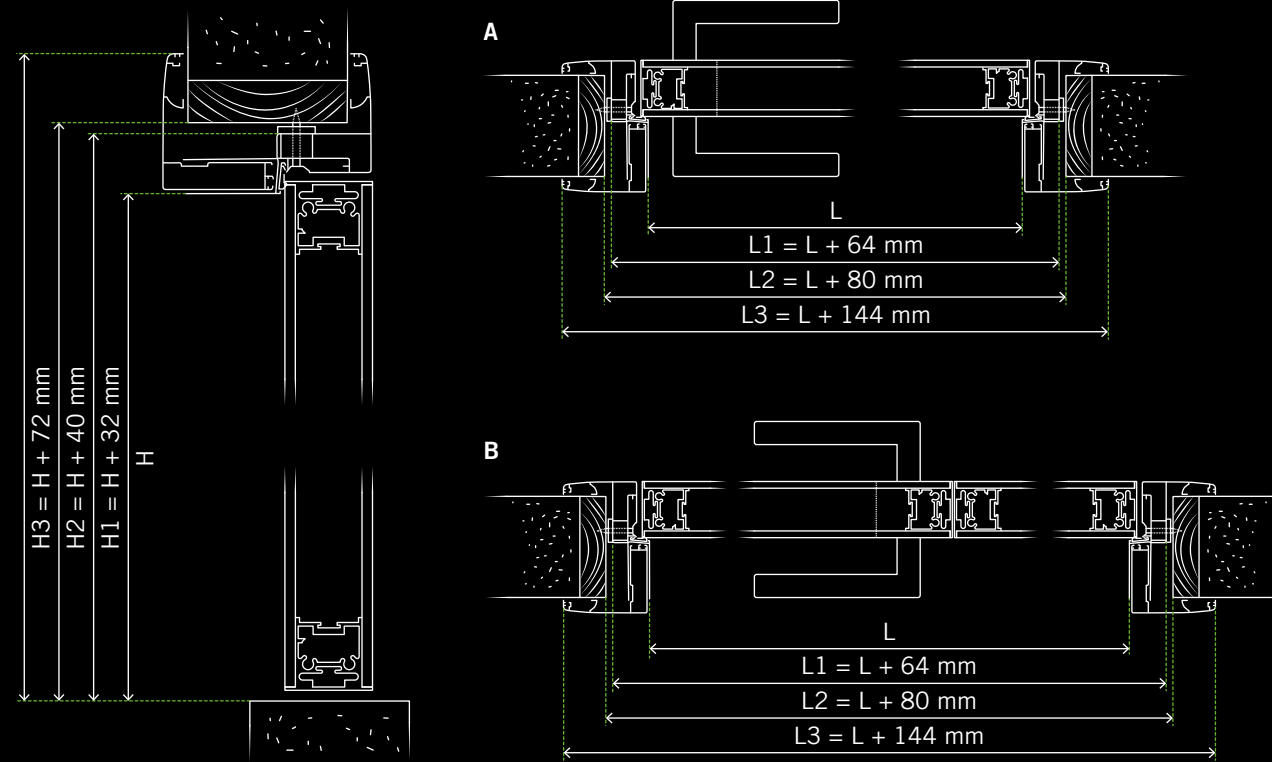

MINIMALE

Porta battente per muro finito
Hinged door for finished wall

- A. Anta singola
Single leaf
- B. Anta doppia
Double leaf

- H Luce netta passaggio
Net passage clearance
- H1 Esterno telaio
External frame
- H2 Interno controtelaio
Internal counter-frame
- L Luce netta passaggio
Net passage clearance
- L1 Esterno telaio
External frame
- L2 Interno controtelaio
Internal counter-frame

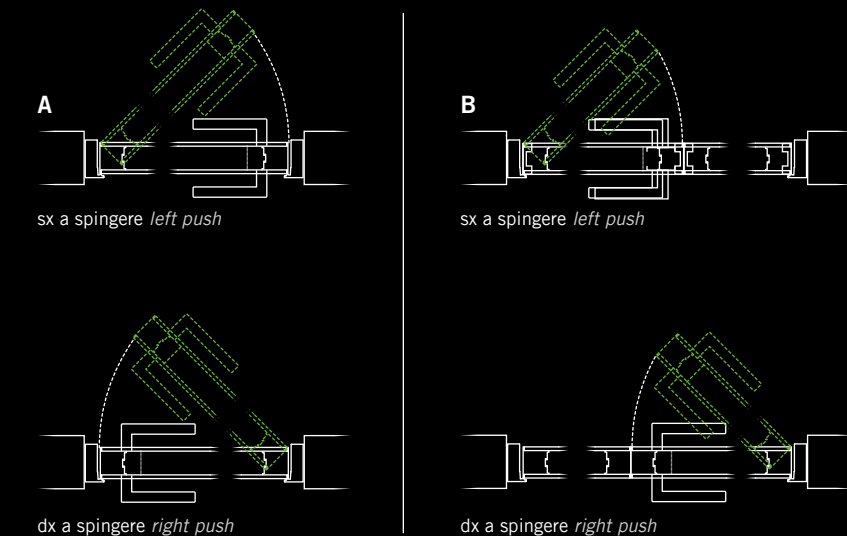
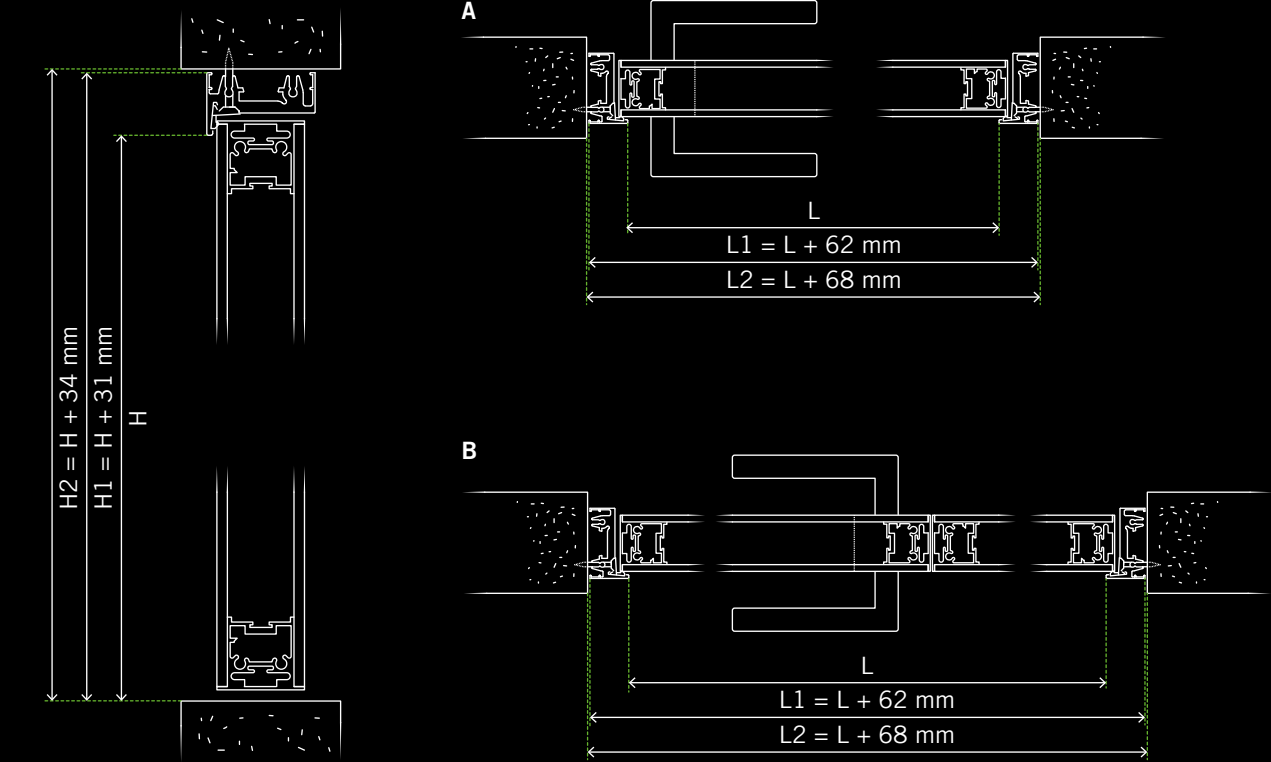

DISEGNI TECNICI / Scorrevoli a scomparsa

TECHNICAL DRAWS / Pocket sliding

TRATTO

Porta scorrevole a scomparsa
Pocket sliding door

- A. Anta singola
Single leaf
- B. Anta doppia
Double leaf

- H Luce netta passaggio
Net passage clearance
- H1 Esterno telaio
External frame
- H2 Esterno cornice
External moulding
- L Luce netta passaggio
Net passage clearance
- L1 Esterno telaio
External frame
- L2 Esterno cornice
External moulding

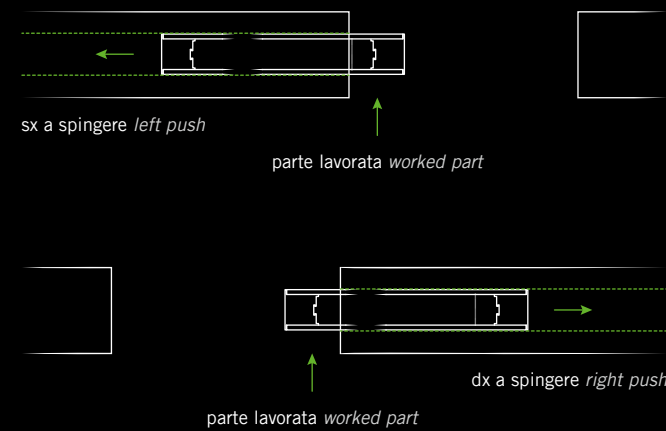
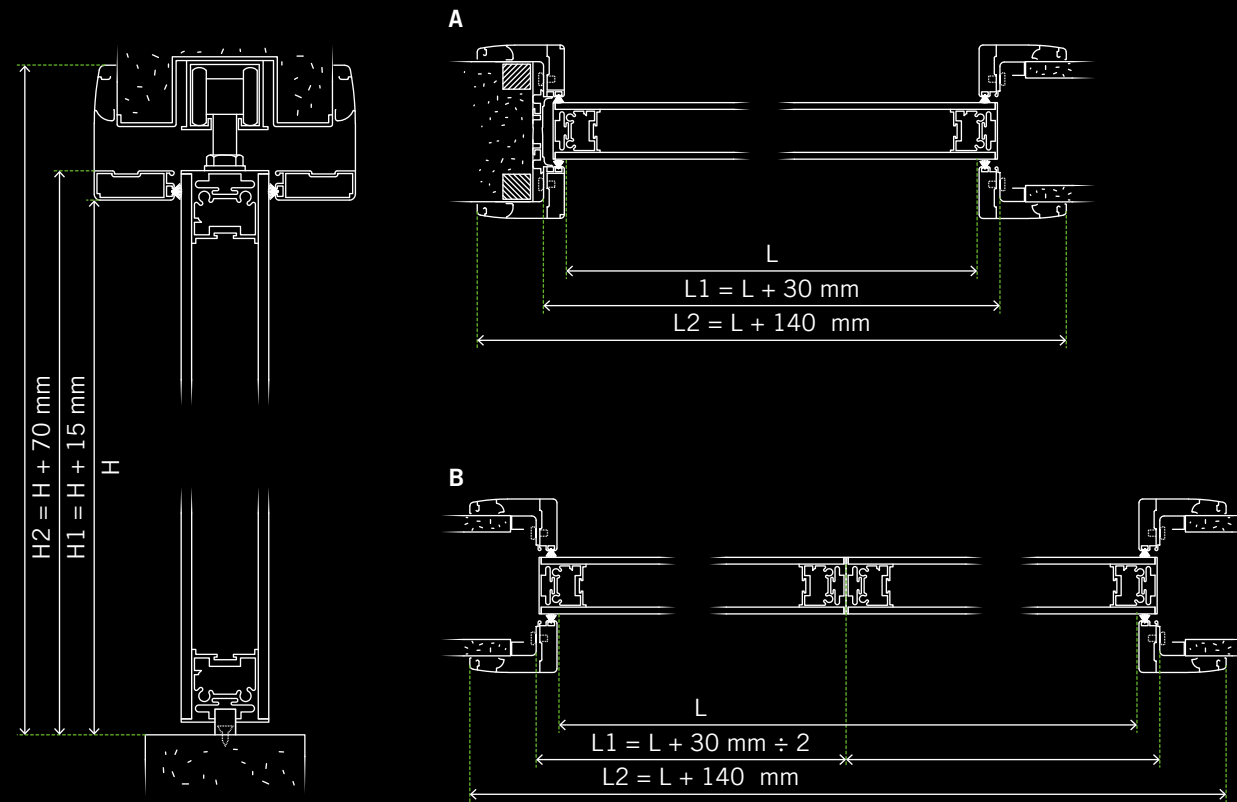

RASOMURO

Porta scorrevole a scomparsa
senza telaio
Pocket sliding door
without frame

- A. Anta singola
Single leaf
- B. Anta doppia
Double leaf

- H Luce netta passaggio
Net passage clearance
- H1 Anta finita
Finished leaf
- L Luce netta passaggio
Net passage clearance
- L1 Anta finita
Finished leaf

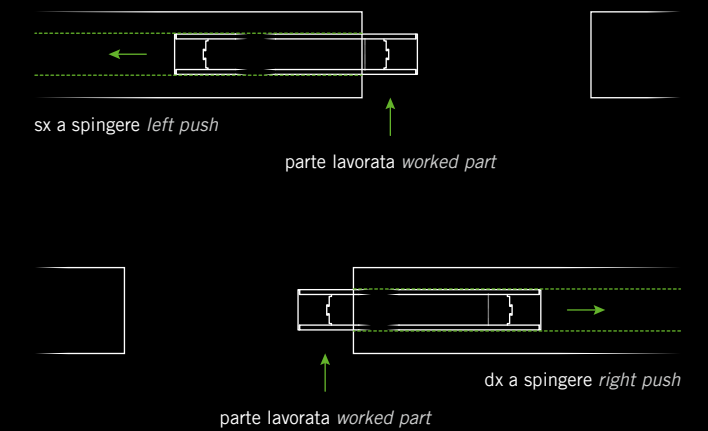
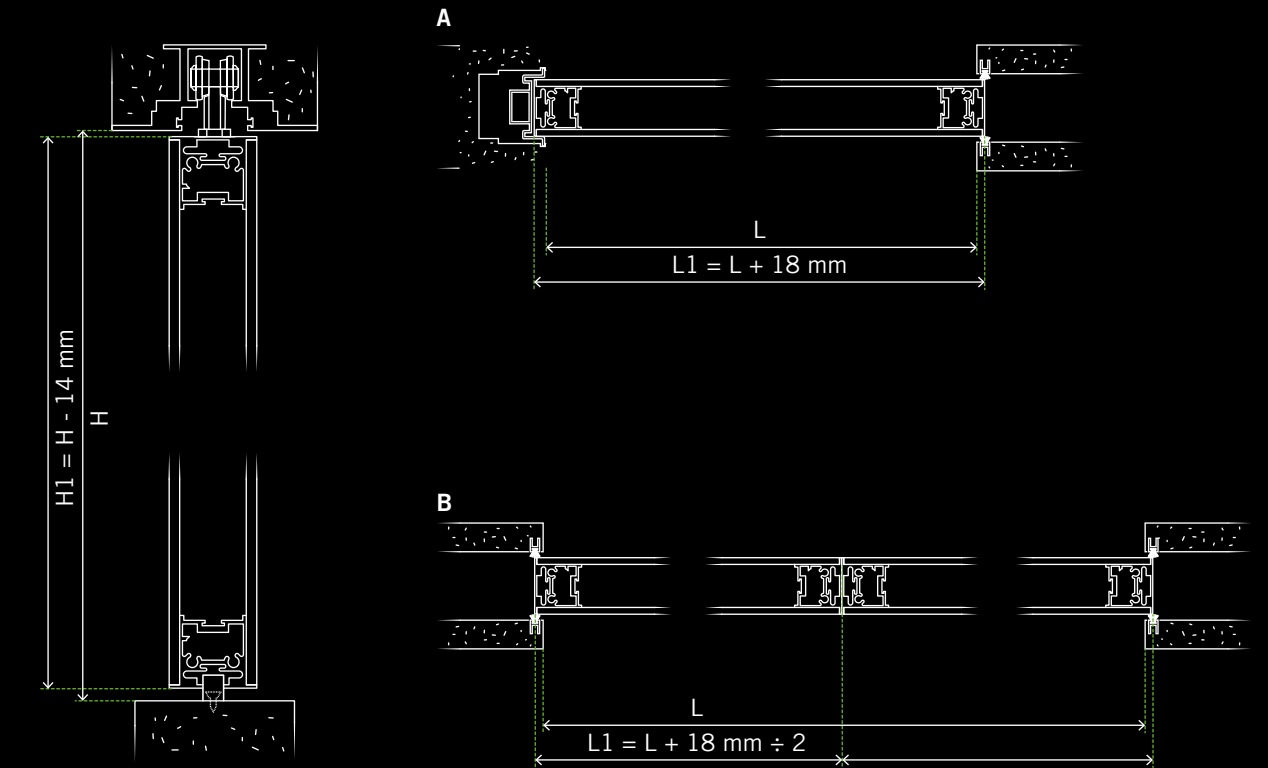

MANIGLIE / Battenti
HANDLES / Hinged door

- 1. Quadra foro patent
Quadra patent hole
- 2. Quadra con nottolino
Quadra with knob



MANIGLIE / Scorrevoli
HANDLES / Sliding door

- 1. Maniglia ovale
Oval handle
- 2. Kit di chiusura
Closure kit





Flessya Srl

via dell'Artigianato 13
60030 Monte Roberto AN
p.iva 02287520429
tel 0731.70.74.11
fax 0731.70.74.70
www.flessya.com
info@flessya.it
commerciale@flessya.it
amministrazione@flessya.it

Amplifica l'esperienza con il nostro catalogo attraverso il tuo tablet, scarica la nostra **App disponibile per Android e iOS** e scopri tutte le informazioni sui nostri prodotti.

All'interno potrai trovare video, esperienze con i prodotti, la possibilità di configurare la tua porta e molto altro.

*Expand experience with our catalogue with your tablet, download our **App available for Android and iOS** and learn everything you need to know about our products.*

You'll find videos, experiences with products, the chance to design your door and much more.



I colori riportati sono puramente indicativi.

The brought colors are purely indicative.

